

STAINLESS STEEL BULB CLAMP KIT

Installation Instructions

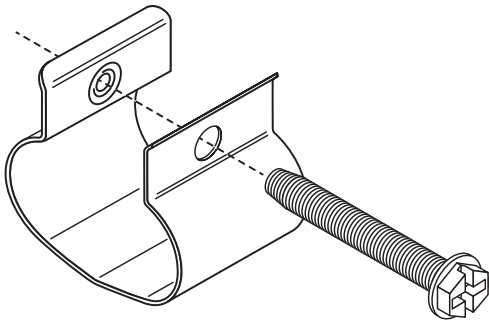

KT-6744-SS-CLAMP-3/4

Use only with the following bulb and suction line sizes.

Bulb Diameter Inches (mm)	Suction Line Diameter Inches (mm)		
	5/8" (16 mm)	3/4" (19 mm)	7/8" (22 mm)
3/4" (19 mm)	✓	✓	✓



**FOR REFRIGERATION and AIR
CONDITIONING APPLICATIONS ONLY**

Bulb Location

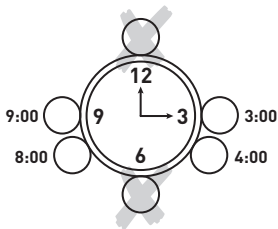
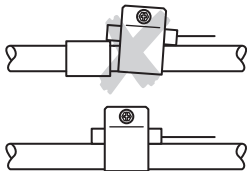

Torque Screw 10 to 15 in. - lb. (1.1 to 1.7 Nm)

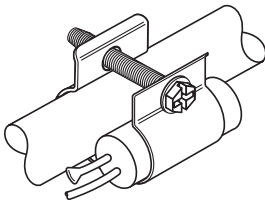

Parker Hannifin Corporation
Sporlan Division
206 Lange Drive, Washington, MO 63090
phone 636 239 1111
www.sporlan.com

SD-373 / 62012

⚠ WARNING – USER RESPONSIBILITY

Failure or improper selection or improper use of the products described herein or related items can cause death, personal injury and property damage.

This document and other information from Parker Hannifin Corporation, its subsidiaries and authorized distributors provide product or system options for further investigation by users having technical expertise.

The user, through its own analysis and testing, is solely responsible for making the final selection of the system and components and assuring that all performance, endurance, maintenance, safety and warning requirements of the application are met. The user must analyze all aspects of the application, follow applicable industry standards, and follow the information concerning the product in the current product catalog and in any other materials provided from Parker or its subsidiaries or authorized distributors.

To the extent that Parker or its subsidiaries or authorized distributors provide component or system options based upon data or specifications provided by the user, the user is responsible for determining that such data and specifications are suitable and sufficient for all applications and reasonably foreseeable uses of the components or systems.