



SPORLAN  
SPORLAN  
SPORLAN  
SPORLAN  
SPORLAN  
SPORLAN

# Pressure Control

Installation and Operation Instructions



Controller v. A



ENGINEERING YOUR SUCCESS.

## Contents

1. Installation . . . . .	3	APPENDIX A	
2. Setup . . . . .	4	Setup Menu . . . . .	12
3. Setpoint Menu Operation . . . . .	4	APPENDIX B	
4. System Operation . . . . .	4	Process Values . . . . .	12
Applications – Low Side, High Side . . . . .	5	APPENDIX C	
Regulating Evaporator Pressure . . . . .	5	Setpoint Parameters . . . . .	12
Regulating Condenser Pressure . . . . .	5	APPENDIX D	
Regulating Receiver Pressure . . . . .	6	Accessories . . . . .	14
Regulating Liquid Pressure . . . . .	6	APPENDIX E	
Advanced Features . . . . .	6	Technical Specifications . . . . .	14
Additional Helpful System Parameters . . . . .	7	APPENDIX F	
Process Value Menu . . . . .	7	Wiring Diagram . . . . .	15
5. Controller Networking . . . . .	8	System Schematic . . . . .	15
Scaling for Celcius / Bar . . . . .	8	APPENDIX G	
Setup . . . . .	8	Modbus Memory Map . . . . .	16
Modbus Connection Requirements . . . . .	8	APPENDIX H	
BACnet Connection Requirements . . . . .	8	BACnet Memory Map . . . . .	18
6. PID Tuning . . . . .	9	APPENDIX I	
AUTO PID Control . . . . .	9	Temperature Sensor Specifications . . . . .	20
MANUAL PID Control . . . . .	9		
7. Troubleshooting . . . . .	9		
Troubleshooting Recommendations . . . . .	9		
Sensors . . . . .	9		
Alarms . . . . .	10		

### **⚠ WARNING – USER RESPONSIBILITY**

**Failure or improper selection or improper use of the products described herein or related items can cause death, personal injury and property damage.**

This document and other information from Parker Hannifin Corporation, its subsidiaries and authorized distributors provide product or system options for further investigation by users having technical expertise.

The user, through its own analysis and testing, is solely responsible for making the final selection of the system and components and assuring that all performance, endurance, maintenance, safety and warning requirements of the application are met. The user must analyze all aspects of the application, follow applicable industry standards, and follow the information concerning the product in the current product catalog and in any other materials provided from Parker or its subsidiaries or authorized distributors.

To the extent that Parker or its subsidiaries or authorized distributors provide component or system options based upon data or specifications provided by the user, the user is responsible for determining that such data and specifications are suitable and sufficient for all applications and reasonably foreseeable uses of the components or systems.

For safety information see the Safety Guide at [www.parker.com/safety](http://www.parker.com/safety) or call 1-800-CParker.

### **OFFER OF SALE**

The items described in this document are hereby offered for sale by Parker Hannifin Corporation, its subsidiaries or its authorized distributors. This offer and its acceptance are governed by the provisions stated in the detailed "Offer of Sale" available at [www.parker.com](http://www.parker.com).

### **FOR USE ON REFRIGERATION and/or AIR CONDITIONING SYSTEMS ONLY**

Bulletin 100-50-5.5, September 2013 supersedes Bulletin 100-50-5.5 dated July 2013 and all prior publications.  
For more information about our products visit us at [www.sporlan.com](http://www.sporlan.com).

## Introduction

The Sporlan **Pressure Control** is a standalone controller used to regulate pressure at a specific location by controlling a Sporlan electric valve. The compact and versatile Pressure Control is flexible for use on both low side and high side of a refrigeration or air conditioning system. It may also be networked via RS-485 for remote access to pressure readings in addition to viewing and editing the controller's setpoints.



## Features

- Flexible configuration to control system low side or high side pressure
- Optional sensors allow monitoring of subcooling or superheat
- Electronic upgrade from mechanical SORIT, A8, A9 and A8OE valves
- 4-digit LED display and input knob
- Modbus and BACnet communication options
- Optional controller networking for remote access
- Four temperature inputs (Sporlan surface or air sensors)
- One pressure input (Sporlan transducers)
- One digital input (for external switch or relay)
- Alarm output

## 1. Installation

Refer to *Appendix F – Wiring Diagram & System Schematic* for common system setup and connections. For additional information on mounting and testing sensors, please consult Sporlan's Pressure Transducer & Temperature Sensor Installation Instructions (Form SD-245).

### TOOLS REQUIRED:

- Small flat screwdriver for terminal connections
- Phillips and flat screwdrivers
- Cordless screwdriver
- Needle-nose pliers
- Wire cutters
- Scotch-Brite™ pad
- Two #8 x 1/2" self-tapping screws to mount DIN rail

### Maximum torque on screw terminals is 3.5 in-lbs.

1. Mount the controller in a rain-tight, protected location using the supplied DIN rail. To leave enough working space, the suggested mounting area is 10 inches (254 mm) high and 5 inches (127 mm) wide. The minimum depth is 3 inches (76.2 mm). See Figures 1 and 2.
2. Attach the pressure transducer cable to terminals 33, 34 and 35, matching the colors shown in the wiring diagram. See Table 1 for transducer cable wire colors. Note: Pressure

transducer location is determined by the application. See *Section 4 – System Operation or Appendix F – Wiring Diagram and System Schematic*.

3. For Evaporator Pressure Regulating applications, mount the optional suction vapor temperature sensor (T1) to the suction line. Connect the sensor wires to terminals 31 and 32. This sensor may be used to monitor and view superheat.
4. For liquid pressure applications, mount the optional Liquid Outlet temperature sensor, (T2) to the tube feeding the expansion valve(s). Connect the sensor wires to terminals 29 and 30. This sensor may be used as a high temperature cut out.
5. For condenser pressure applications, mount the optional Liquid Inlet temperature sensor, (T3) to the tube leaving the condenser, "drop leg." Connect the sensor wires to terminals 27 and 28. This sensor may be used to monitor and view subcooling.
6. Connect terminals 25 and 26 to a digital input. A short or closed contact from an external relay will enable pumpdown and drive the valve to 0% or 100% based upon P<sub>dd</sub>.
7. Connect the Sporlan electric valve wires to terminals 5, 6, 7 and 8, matching the colors shown in the wiring diagram.
8. Connect power wires to terminals 1 and 2. Transformer requirements are 24 volts AC at 40VA, Class II.
9. Remove the protective clear film cover from the front of the Pressure Control.

**NOTE: Sensor leads may be extended to 100 ft. (30.5 m) with 18 awg wires and Scotchlok™ UR connectors for long-term integrity.**

Table 1 - Pressure Transducer Wire Colors

	CONTROLLER TERMINAL	OLD PIGTAIL LEADS	NEW HERMETIC CABLE
+	35	Red	Black
S	33	Green	White
-	34	Black	Green

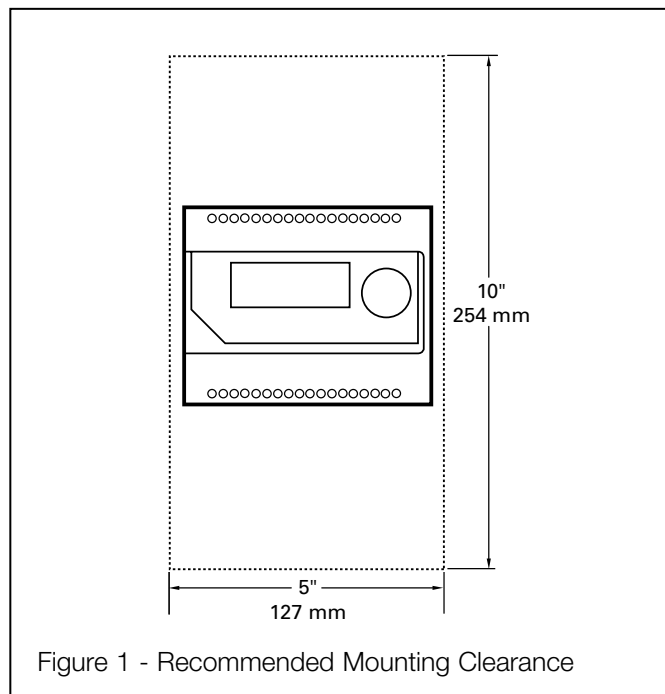
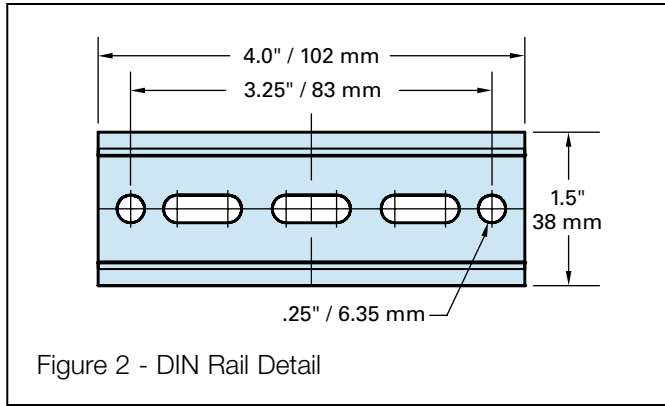

Figure 1 - Recommended Mounting Clearance



**WARNING:** Route and secure cables away from hot surfaces, high voltage lines, and moving components.

**NOTE:** The Sporlan Pressure Control should be installed only by a qualified professional. All other system components (valves and sensors) should be supplied by Sporlan to ensure compatibility and proper operation. There are no user-serviceable components inside the Pressure Control. Opening the case will void the warranty.

**WARNING:** Use caution when working around high voltage components. Safety covers should be used for personal safety on high voltage panels.

## 2. Setup

### PRESSURE CONTROL

The Pressure Control must be configured prior to starting the system. Basic system parameters will be established through the setup menu. If additional presets need to be changed, follow the steps in this section and in *Section 3 – Setpoint Menu Operation*.

**NOTE:** The refrigeration or air conditioning system must be off until set up has completed.

Enter values for 4 system variables following the steps below. Refer to *Appendix A – Setup Menu*. The electric valve is closed upon power-up and the system will not operate until completing start up. The controller will display the firmware versions for the display and the controller. It will then display the first variable to set.

1. Set **APPL**, Control Application. Press and then turn the SELECT knob to set the application. For low side applications, select **EP<sub>r</sub>**, Evaporator Pressure Regulator. For high side applications, select **Cond** for Condenser Pressure Regulator (Holdback), **rEc** for Receiver Pressure Regulator or **LP<sub>r</sub>** for Liquid Pressure Regulator. Press the SELECT knob to save the value. The next variable is displayed.
2. Set **Prn<sub>g</sub>**, Pressure Transducer Range. Select the correct pressure range for the transducer being used. Press the SELECT knob to save the value.
3. Set **PSP**, Pressure Setpoint. Select the desired pressure setpoint for the system.
4. Set **StEP**, Valve Steps. Select the correct number of steps for the electric valve being used. Refer to Table 2. Press the SELECT knob to save the value.

**NOTE:** The Pressure Control will automatically configure the control setpoints based on the application selected. See Table 3 for common set-up configurations and defaults.

**NOTE:** Optional temperature sensors can be added to enable additional features of the Pressure Control. See *Section 4 – System Operation*.

The Pressure Control is now operational and displaying the Process Values Menu (*Appendix B*). To view system parameters while in operation, turn the SELECT knob and scroll through the menu. Select the desired parameter. For example, to view the valve position, turn the SELECT knob to **Posn**. After a few seconds, the actual valve position will be displayed. See *Appendix B – Process Values* for a description of each variable.

Table 2 - Sporlan Electric Valves

SPORLAN MODEL NUMBERS	STEPS
SDR-1x, SDR-2, SDR-2x	1596
CDS-2, CDS-4, CDS-7	2500
SDR-3, SDR-3x	3193
CDS-9, CDS-17, SDR-4, SDR-5	6386

## 3. Setpoint Menu Operation

See *Appendix C – Setpoint Parameters*. All setpoints should be verified to ensure proper system operation. It may be necessary to adjust these parameters for a specified system. Details on advanced features can be reviewed in *Section 4 – System Operation*.

1. Enter the Setpoint Menu: Press the SELECT knob for 5 seconds. Enter the password and press the SELECT knob again. (The controller’s default password is ‘111’)
2. To view a parameter, rotate the SELECT knob to the desired parameter and press the knob. The default value will be displayed.
3. Turn the SELECT knob to change the value and then press the SELECT knob to enter the value and return to the Setpoint Menu.
4. After all the desired parameters are set, turn the SELECT knob to “ESC” and press the knob to save and implement all changes. Observe the system for proper operation.

**NOTE:** The Setpoint Menu times out after 60 seconds of inactivity and you will lose all changes entered.

**NOTE:** Not all refrigeration systems are designed alike. See *Section 7 – PID Tuning* to adjust the settings according to the specific needs of the system.

## 4. System Operation

The Sporlan Pressure Control can be set up to support several types of system configurations for low and high side pressure applications. The most common low side application uses a single pressure set point. In this application, evaporator pressure is controlled by regulating an Electric Evaporator Pressure Regulating Valve (EEPR), such as Sporlan’s type CDS(T). For convenience, an optional temperature sensor is

available to monitor and display superheat in the suction line of the evaporator it is controlling. Additional control options include high side pressure regulation for the condenser, receiver and liquid pressure. Optional temperature sensors are also available to monitor and display subcooling (condenser holdback applications) and provide a cut out temperature (liquid pressure applications). Typical configurations can be seen in Table 3. For additional applications, contact Sporlan Division to ensure proper system performance and reliability.

The Sporlan Pressure Control uses the pressure input to maintain the setpoint, *PSP*. For low pressure applications, it is recommended to use a 150 psi or 300 psi transducer. For high side applications, it is recommended to use a 300 psi or 500 psi transducer. The transducer must operate within -40 to 257°F [-40 to 125°C] and can be exposed to system pressures up to 2x rated pressure of the transducer.

Valve control is determined by the application parameter, *APPL*. If non-default parameters are needed, the Pressure Control may be manually configured by entering the Setpoint Menu and adjusting the pressure rise valve direction parameter, *PrUd*. The controller can be configured to either open the valve as the pressure rises (*oPPr*) or close the valve as the pressure rises (*CLPr*). The pumpdown valve direction parameter, *Pdd* may be adjusted for “open on pumpdown” or “close on pumpdown.” Pumpdown is enabled by an external signal and may be used to position the valve during certain system operating conditions. For full details on pumpdown operation see *Advanced Features* in this section.

If an error should occur on the pressure input circuit, the valve will be positioned at the sensor failure valve position, *SEFP*. The failure position may be adjusted in 25% valve position increments. See Table 3 for recommended configurations and defaults for the listed applications.

If the system requires that the default parameters be changed, the application parameter, *APPL*, must be selected first before adjusting the additional parameters.

**NOTE: If using non-default parameters, the Sensor Failure Valve Position, *SEFP*, must be verified prior to starting the system.**

## LOW SIDE APPLICATION

### Regulating Evaporator Pressure (*EP<sub>r</sub>*)

For systems that require a SORIT or equivalent mechanical pressure regulator for evaporator pressure control, an electric valve Sporlan Type CDS(T) may be installed along with a pressure transducer.

The pressure transducer must be installed on the suction line according to the evaporator or system manufacturer’s recommendation. The Sporlan Pressure Control may be used

to control a single evaporator or used on a common suction line to control the pressure in a lineup of evaporators. The controller should be configured to “Open on Pressure Rise.” The pumpdown direction and sensor failsafe valve position must also be set to ensure correct system operation. In this arrangement, the controller will regulate the electric valve to decrease evaporator pressure when the pressure input rises above set point.

Suction line superheat may be monitored and displayed by installing the optional T1 coil outlet temperature sensor, *LoUt*, and entering the refrigerant type, *rEFr*, found in the setpoint menu. The sensor must be located on the suction line leaving the evaporator in close proximity to the pressure transducer. Refer to *Appendix F* for an example system schematic.

## HIGH SIDE APPLICATIONS

See Table 4 for example system setpoints when using Sporlan Pressure Control. The chart is included only to show how to set up each component on the system high side to ensure best performance. The example setpoints may not necessarily be the appropriate setpoints for your particular system. In the example the system should maintain a liquid pressure (feeding the expansion valves) between 130 psi (9 bar) and 160 psi (11 bar).

### Regulating Condenser Pressure (*C<sub>ond</sub>*)

For systems that require an A8 or equivalent mechanical pressure regulator for condenser “hold back,” an electric valve Sporlan type CDS(T) may be installed along with a pressure transducer. The pressure transducer must be installed between the condenser outlet and the CDS(T). The t-port on the inlet of the CDST may be used to mount the transducer.

The controller should be configured to “Open on Pressure Rise.” It is recommended that the pump down direction be set to Open and the sensor failsafe valve position be set to 100%.

**NOTE: Take precaution when changing the pressure rise valve direction, pumpdown direction and sensor failsafe valve position. For condenser holdback applications it is important not to close the valve at any time outside of normal control or maintenance. If the valve closes during system operation, high pressure safety limits may trip (if installed) and equipment damage could occur.**

**NOTE: For proper functionality of the Sporlan Pressure Control, the system must be properly charged to accommodate condenser flooding during low ambient conditions. Failure to do so may result in system or product damage. Follow all receiver manufacturer and system design requirements on refrigerant liquid levels to avoid hydraulic conditions.**

**NOTE: To avoid potential high pressure conditions during system power loss and restart, it is recommended that**

Table 3 – Recommended Configurations (Defaults)

SYSTEM APPLICATION	MECHANICAL EQUIVALENT	APPLICATION <i>APPL</i>	CONTROL <i>PrUd</i>	PUMPDOWN <i>Pdd</i>	SENSOR FAILURE <i>SEFP</i>
Evaporator Pressure	SORIT	<i>EP<sub>r</sub></i>	<i>oPP<sub>r</sub></i>	<i>CLPd</i>	0%
Condenser Pressure	A8	<i>C<sub>ond</sub></i>	<i>oPP<sub>r</sub></i>	<i>oPP<sub>d</sub></i>	100%
Receiver Pressure / Hot Gas Bypass	A9	<i>rEC</i>	<i>CLPr</i>	<i>CLPd</i>	0%
Liquid Pressure / Crankcase Pressure	A8OE / CRO	<i>LPr</i>	<i>CLPr</i>	<i>oPP<sub>d</sub></i>	100%

**the system or rack controller be set with a minimum compressor delay of 90 seconds.**

The controller will regulate the electric valve to maintain a minimum pressure as defined by the setpoint *PSP*. Typically, during high ambient temperatures, the electric valve will move to the 100% position to minimize liquid line pressure drop. During low ambient temperatures, the electric valve will regulate condenser pressure.

In general, the condenser fan control logic will set a maximum condensing pressure limit (cut-in) and a minimum condensing pressure limit (cut-out). It is recommended to adjust the fan control cut-out setpoint as described below to allow the Sporlan Pressure Control to manage the amount of liquid in the condenser when liquid holdback is desired. This is required in areas where ambient temperatures are low and flooded condenser designs are used. To ensure correct operation between the condensing fan controls and the Sporlan Pressure Control, the fan cut-out pressure should normally be set to approximately 10 psi (0.7 bar) below the setpoint *PSP*. For example, if *PSP* is 150 psi (10.3 bar) then the fan cut-out pressure should be 140 psi (9.7 bar). See Table 4.

Condenser subcooling may be monitored and displayed by installing the optional T3 liquid inlet temperature sensor, *L in*, and entering the refrigerant type, *rEFr*, found in the setpoint menu. The sensor must be located on the drop leg of the condenser in close proximity to the pressure transducer. Refer to *Appendix F* for an example system schematic.

**REGULATING RECEIVER PRESSURE (*rEc*)**

For systems that require an A9 or equivalent mechanical pressure regulator for receiver pressurization, an electric valve Sporlan type SDR may be installed along with a pressure transducer. The pressure transducer must be installed between the outlet of the electric valve and receiver. The transducer may also be installed directly on the receiver.

The controller should be configured to “Close on Pressure Rise.” It is recommended that the pump down direction be set to Close and the sensor failsafe valve position be set to 0%.

The controller will regulate the electric valve to maintain a minimum pressure as defined by the setpoint *PSP*. Typically, during high ambient temperatures, the electric valve will move to the 0% position to route all discharge gas through the condenser. During low ambient temperatures, the electric valve will modulate and bypass discharge gas to regulate receiver pressure.

The *PSP* should be set approximately 20 psi (1.4 bar) lower than the condenser pressure regulator set point. See Table 4. Refer to *Appendix F* for an example system schematic.

**REGULATING LIQUID PRESSURE (*LP<sub>r</sub>*)**

For systems that require an A8OE or equivalent mechanical pressure regulator for liquid pressure, a Sporlan electric valve type CDS(T) may be installed along with a pressure transducer. The pressure transducer must be installed on the outlet of the electric valve on the liquid line feeding the expansion valves.

The controller should be configured to “Close on Pressure Rise.” It is recommended that the pump down direction be set to Open and the sensor failsafe valve position be set to 100%.

The controller will regulate the electric valve to maintain a maximum pressure as defined by the setpoint *PSP*. The *PSP*

should be set to approximately 10 psi (0.7 bar) above the condenser pressure regulator setpoint. See Table 4.

The Sporlan Pressure Control offers a cut-out feature to minimize liquid line pressure drop during high liquid temperature conditions. To use this feature, the optional T2 liquid outlet temperature sensor, *L out*, must be installed on the liquid line feeding the expansion valves and entering the desired cut-out temperature, *tCo*, found in the setpoint menu. When the liquid temperature is at or above the cut-out temperature, the electric valve will move to the 100% position. Refer to *Appendix F* for an example system schematic.

Table 4 – Example High Side System Set-Points

SYSTEM APPLICATION	PRESSURE AWAY FROM CONDENSER SET POINT	EXAMPLE SET-POINTS
Liquid Pressure Regulator	+10 psi (0.7 bar)	160 psi (11 bar)
Condenser Pressure Regulator	0	150 psi (10.3 bar)
Condenser Fan Low Pressure Cut-Out	-10 psi (-0.7 bar)	140 psi (9.7 bar)
Receiver Pressure Regulator	-20 psi (-1.4 bar)	130 psi (9 bar)

**ADVANCED FEATURES**

**Pumpdown / Full Open**

Closing or shorting terminals 25 and 26 (T4) places the controller in pumpdown mode and positions the valve based upon the parameter *Pdd*. A standard dry contact relay should be used. During pumpdown, the controller will shut down the control scheme. Once the short is removed, the controller will resume normal operation. This feature may be used to force the valve to 100% position or 0% position.

**Manual Valve Position**

The Pressure Control can be used to manually control the electric valve, either locally or remotely. Access the Setpoint menu and change *SPoS* to the desired valve position (between 0 and 100% of full stroke). The system will time out after 60 minutes of inactivity while in manual control. To end manual control, press the SELECT knob (the controller will return to the menu and now display *SPoS*).

The electric valve can also be manually controlled via Modbus or BACnet. Writing a 1 to the “Manual Valve Enabled” coil, or Active to the “Manual-Valve Control” Object, activates manual valve control, and the desired valve position can then be written to the “Manual Valve Position” register, see *Appendix G – Modbus Memory Map*, or *Appendix H – BACnet Memory Map*.

**Note: Caution should be taken when manually controlling the electric valve. Closing the valve while the system is running may cause high pressure limits to trip (if installed), equipment damage or personal injury. The system must never be left unattended in manual valve mode.**

**Temperature Cut-Out**

For liquid pressure regulator applications, the optional T2 liquid outlet temperature sensor, *L out*, may be installed on the liquid line feeding the expansion valves and entering the desired cut-out temperature, *tCo*, found in the setpoint menu. When the liquid temperature is at or above the cut-out

temperature, the electric valve will move to the 100% position. This feature can be used to minimize liquid line pressure drop across the electric valve and help maintain subcooling when the liquid temperature becomes too high. Refer to *Appendix F* for an example system schematic.

### Subcooling

For condenser and liquid pressure regulator applications, subcooling, *SUBC*, may be monitored and displayed by installing the optional T3 liquid inlet temperature sensor, *L IN*, and entering the refrigerant type, *REFR*, found in the setpoint menu. For condenser pressure regulator applications, the sensor must be located on the drop leg of the condenser. For liquid pressure regulator applications, the sensor must be located on the liquid line feeding the expansion valves. Both applications required that the sensor be mounted in close proximity to the pressure transducer. Refer to *Appendix F* for an example system schematic.

### Superheat

For low side evaporator pressure regulator applications, suction line superheat, *SUPH*, may be monitored and displayed by installing the optional T1 coil outlet temperature sensor, *COUT*, and entering the refrigerant type, *REFR*, found in the setpoint menu. The sensor must be located on the suction line leaving the evaporator in close proximity to the pressure transducer. Refer to *Appendix F* for an example system schematic.

## ADDITIONAL HELPFUL SYSTEM PARAMETERS

**Temperature Sensor Type, *TEMP*** – specifies the type of temperature sensor being used. The Pressure Control can accept 2K, 3K or 98.6K Sporlan temperature sensors. However, all temperature sensors connected to the Pressure Control must be the same type.

**Pressure Transducer Range, *PRNG*** – the range of available pressure transducers that the controller supports; *150A* denotes absolute. *150*, *300* and *500* denotes gauge. The control range will be 90% of the maximum range selected. For example, if a 500 psi transducer is selected, the pressure setpoint, *PSP*, may be set up to 450 psi (31 bar).

**Sensor Error Failsafe Position, *SEFP*** – the position that the controller will place the valve if pressure transducer failure occurs.

**Maximum Valve Position, *UHI*** – the maximum position (% open) that the controller will position the valve during normal operation. This parameter is ignored when the controller is in manual mode or when setting *SEFP* is enabled due to sensor failure.

**Minimum Valve Position, *ULO*** – the minimum position (% open) that the controller will position the valve during normal operation. This parameter is ignored when the controller is in manual mode or when setting *SEFP* is enabled due to sensor failure. For condenser pressure regulator applications, it is recommended that the default minimum valve position be used.

**High Alarm Value, *PSIH*** – the pressure threshold for high pressure alarm.

**Low Alarm Value, *PSIL*** – the pressure threshold for low pressure alarm.

**High Alarm Delay, *PSdH*** – the delay, in minutes, after the measured pressure exceeds *PSIH* before the high pressure alarm is activated.

**Low Alarm Delay, *PSdL*** – the delay, in minutes, after the measured pressure falls below *PSIL* before the low pressure alarm is activated.

**Pressure Units, *Un\_P*** – the preferred unit type for pressure; selectable in PSI (*PSI*) or Bar (*BAR*).

**Temperature Units, *Un\_t*** – the preferred unit type for temperature; selectable in Fahrenheit (*FAHR*) or Celsius (*CELS*).

**Pressure Calibration, *PCAL*** – the allowable offset that can be used for the pressure input.

**Network Type, *nEt*** – the type of network that the system or enterprise controller uses; selectable in Modbus (*nBUS*) or BACnet (*bnEt*).

**Refrigerant Type, *REFR*** – the system refrigerant type; see *Appendix C* for a full list of supported refrigerants. This parameter is only used if subcooling or superheat monitoring and display is required (optional temperature sensor must be installed).

## PROCESS VALUE MENU

During operation, the controller status can be viewed through the Process Value menu. When no other operation is active, the controller will display the Process menu. By default, the display will read *PRE5* followed by the current pressure reading measured from the transducer. Rotating the SELECT knob will allow the user to view the following:

**System Pressure, *PRE5*** – displays the current pressure measured by the transducer.

**Current Valve Position, *PO5n*** – displays the current position of the valve as % open.

**Pumpdown Status, *StAt*** – displays whether the controller is currently in pumpdown mode (*Pdn* = enabled) or normal operation (*dISA* = disabled).

**Temperature Cut-Out Status, *tCut*** – displays whether the controller is in cut-out mode (*EnAb* = enabled) or in normal operation (*dISA* = disabled). This feature can only be used when optional temperature sensor, *Lout*, is installed.

**Alarm Status, *ALS*** – displays a list of all active alarms on the controller. If no alarms are active, the controller will display *nonE*.

**Evaporator Outlet Temperature, *COUt*** – displays the current temperature measured by the temperature sensor T1. This feature is only used when low side application is selected and suction superheat monitoring and display is required.

**Liquid Outlet Temperature, *LOUt*** – displays the current temperature measured by the temperature sensor T2. This feature is only used when high side application is selected and liquid line temperature cut-out is required.

**Liquid Inlet Temperature, *L IN*** – displays the current temperature measured by the temperature sensor T3. This feature is only used when high side application is selected and drop leg or liquid line subcooling monitoring and display is required.

**Auxiliary Temperature, *AuT4*** – displays the current temperature measured by auxiliary temperature sensor T4.

**NOTE:** this input is also used to activate pumpdown mode on the controller.

**Subcooling, *SUBC*** – displays the current drop leg or liquid subcooling value measured by the pressure transducer and liquid temperature sensor, *L<sub>in</sub>*. This feature is only used on condenser and liquid pressure regulator applications and when the system refrigerant is entered. Display will show nA when refrigerant is not selected.

**Superheat, *SUPH*** – displays the current suction superheat value measured by the pressure transducer and evaporator outlet temperature sensor, *t<sub>out</sub>*. This feature is only used on low side applications and when the system refrigerant is entered.

## 5. Controller Networking

The Sporlan Pressure Control can communicate with a Modbus or BACnet communication master via RS485 to transfer process values and setpoints. See *Appendix G – Modbus Memory Map* or *Appendix H – BACnet Memory Map*.

The Pressure Control supports only the RTU transmission mode. The serial settings are:

- 9600 baud (default), 19200 baud, 38400 baud
- 8 data bits
- 1 stop bit
- Even parity (default), odd parity, no parity

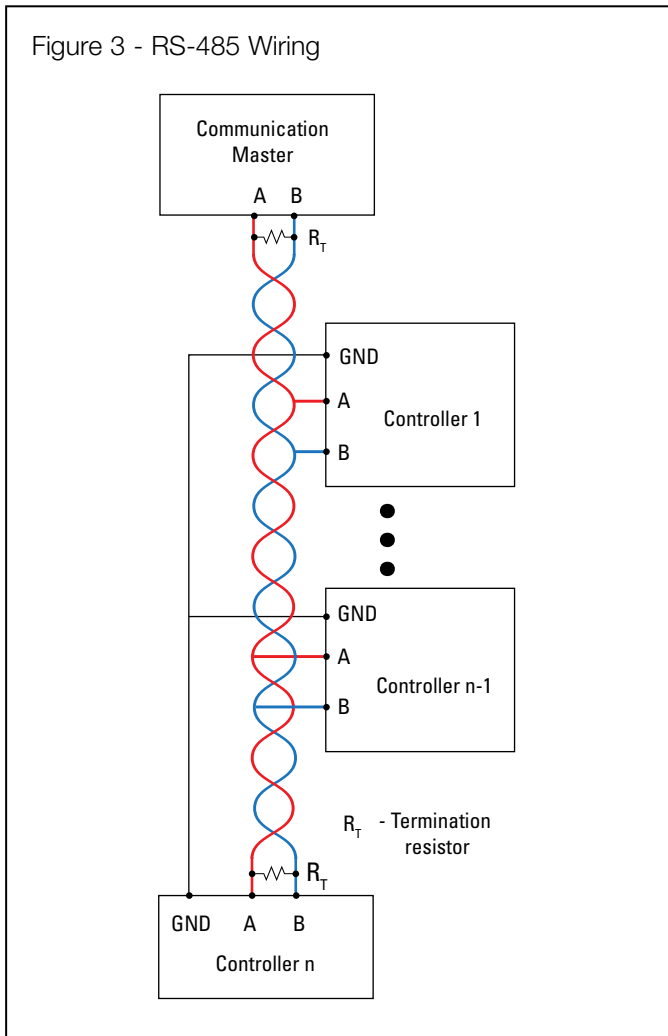

## Scaling for Celsius / Bar

For better precision, scaling is used for Bar or Celsius units. PSI and Fahrenheit are whole numbers and have no scaling.

Celsius values transferred via Modbus or BACnet are 10X. For example, a value of 45 will be transferred for the superheat when the actual superheat temperature is 4.5°C. Remember this when changing a setpoint.

Bar values transferred via Modbus or BACnet are 100X. For example a value of 1034 will be transferred for the Maximum Operating Pressure when the actual pressure is 10.34 Bar. Remember this when changing a setpoint.

## Setup

The Sporlan Pressure Control can be networked to communicate process variables back to a master controller. This information can be used for verifying system performance or updating individual setpoints via RS-485 and PC interface. Data can be accessed remotely through the master controller. For further information on remote monitoring, see the documentation for the master controller.

Prior to connecting the network, each controller must be assigned a separate address on the Modbus or BACnet network, *Addr*. Refer to *Section 3 – Setpoint Menu Operation* to enter the Setpoint menu. Once in the Setpoint menu, scroll to *Addr* and assign each controller on the network an individual address. Note that no two controllers can have the same address. Default address for each controller is '1.'

**NOTE:** *Addr* is the network address, *CAddr* is the controller display address.

## Modbus Connection Requirements

See *Figure 3 - RS-485 Wiring*.

**Wire Type:** 18 AWG Universal Twisted Pair

**Maximum Number of Network Nodes:** 100

**Maximum Run Length:** 4000 ft

**Recommended Network Configuration:** Daisy Chain, a single continuous transmission line from one end to the other. See *Figure 4*. Other configurations involving triple-lug connections, such as star, are not recommended.

**Noise Reduction:** Termination resistance (RT in Figure 3) is recommended to reduce reflections and noise on the data transmission lines. Place the resistance at the extreme ends of the cable, with the resistance value matching the characteristic impedance of the transmission line (typically 120 ohms for twisted pair cables).

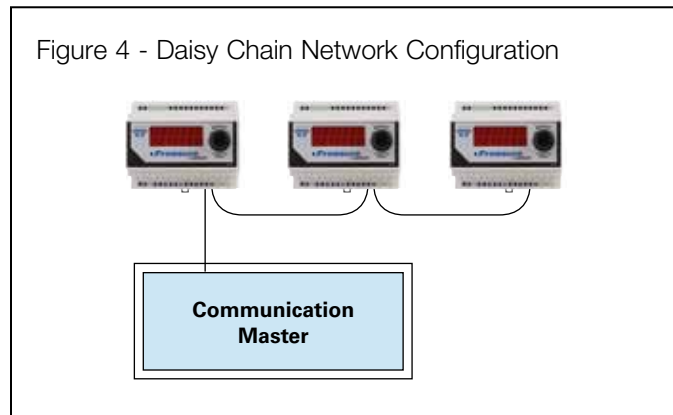



Shielding prevents noise from EMI sources. If the cable is shielded, connect the shield to earth ground at one end only.

**NOTE: Do not connect shield to RS-485 GND.**

Keep RS-485 wiring away from high voltage AC lines to reduce noise and data errors on the communication lines. If necessary, RS-485 communication cable should be placed perpendicular to AC lines at any intersection.

**Grounding:** Connect an optional third conductor to RS-485 GND (terminal 13) to prevent ground potentials between nodes. This conductor should be included in the shield of the twisted pair cable to prevent noise. **NOTE: Do not connect RS-485 GND to earth ground.**

**Third Party Controllers:** To avoid nuisance “network errors,” the use of third-party controllers on the same RS-485 network with Sporlan controllers is not recommended.

See *Appendix G – Modbus Memory Map* or *Appendix H – BACnet Memory Map*. Also, refer to the documentation supplied with the communication master for additional RS-485 network requirements.

## 6. PID Tuning

PID (Proportional-Integral-Derivative) setpoints can greatly affect system performance. These setpoints alter how the electric valve operates to maintain pressure setpoint. In general, the Proportional setpoint adjusts valve response based on “error” (actual pressure vs. desired); Integral setpoint adjusts valve response based on “error over time”; and Derivative setpoint adjusts valve response based on “rate of change.”

To simplify tuning, the Pressure Control offers a default AUTO PID control to minimize the need to manually tune PID settings. For experienced users, a MANUAL PID control is available to fine tune the system as needed. It is recommended that AUTO PID be used.

**NOTE: Before manual PID is selected, ensure that system performance is not affected by other valves, controls or system components upstream or downstream from the Pressure Control valve. A hunting TEV, faulty evaporator fan or blocked coil may cause unstable Pressure Control performance. Adjust or tune other system components prior to selecting MANUAL PID mode.**

### AUTO PID Control

The Pressure Control offers a default AUTO PID to simplify system start up. This feature uses a unique control scheme to minimize system oscillations and improve Pressure Control. In most cases, the controller should remain in AUTO PID mode.

### MANUAL PID Control

**NOTE: Only experienced professionals should access this feature. System stability and performance may be improved by adjusting PID. If PID adjustments are made, allow adequate time for the system to respond to the changes.**

If PID settings need to be adjusted due to poor system performance, the PID Control Setting, *Ctrl*, must first be set to “PID.” The *- P -*, *- I -*, and *- d -* settings can then be set manually. See *Section 3 – Setpoint Menu Operation* for accessing the menu.

PID setpoints may be adjusted if the pressure is oscillating around setpoint at steady state conditions or if the system is experiencing poor temperature pull down. In most instances, adjustments to the PI setpoints are adequate. The following guidelines should be followed:

1. *- P -* (Proportional Coefficient) – Increase value to increase valve response to pressure; reduce value to minimize oscillations around setpoint.
2. *- I -* (Integral Coefficient) – Increase value to increase valve response to pressure over a given time period; reduce value to minimize setpoint offset.
3. *- d -* (Derivative Coefficient) – Increase value to increase valve response to rate of change in pressure; reduce value if valve movement is sporadic.

When the pressure is oscillating to extremes, the Proportional and/or the Integral value may be too high. If pressure is slow to react to a transient system change, then the Proportional and/or Integral value may be too low.

## 7. Troubleshooting

### TROUBLESHOOTING RECOMMENDATIONS

As with any refrigeration component troubleshooting, actual system conditions should be verified with a gauge set and a calibrated temperature sensor. This system information is valuable in determining whether it is component related or system related.

### SENSORS

#### Pressure Transducer

Failed pressure transducers will trigger an alarm, which will persist until the problem is corrected. See Table 6 for a list of alarms.

Pressure transducers must be installed tight enough to depress the valve stem in the fitting. Failure to do so will result in erroneous pressure readings and possibly leaks.

Pressure transducers should be tested while connected to the controller and powered. Test at the controller terminals. Voltage between terminals 34 and 35 should be 4.8 to 5.2 volts DC. Voltage between 33 and 34 should be between 0.5 and 4.5 volts DC. See Table 1 – Pressure Transducer Wire Colors.

To test the accuracy of the transducer, connect a gauge set to obtain the actual system pressure. For volts-to-pressure conversion, measure the voltage between terminals 33 and 34. Identify the pressure transducer used and find the correct range *Prrng* in Table 5.

Substitute the measure voltage (V) in the formula in the PSI column. The result should be within 3 psi of the actual system pressure shown on the gauge set. If not, check transducer for proper installation, correct schrader valve, and verify the pressure range identified on the transducer.

To test the transducer cable, disconnect the cable from the transducer and check for 4.8 to 5.2 volts between terminals + and -. See Figure 5 – Pressure Sensor Cable.

#### Temperature Sensor

Failed temperature sensors will not alarm. The sensors may read extremely low or infinite resistance when tested with

an ohmmeter. Readings should be taken with the sensor disconnected from the controller. A missing or disconnected temperature sensor will read **-50** on the display.

Temperature sensor accuracy can be checked by measuring the voltage across the sensor. With the controller powered on and the sensor connected, measure the DC voltage between the sensor's two terminals on the controller. Compare this voltage to the expected values in *Appendix I – Temperature Sensor Specifications*.

### Alarms

When certain pressure or equipment problems arise, the Pressure Control will activate an alarm. See Table 6 for a complete list of alarms and how the controller responds when each alarm is active. To view alarms from the Process Menu, rotate the SELECT knob until the display reads **AL5**. The controller will now display all the active alarms, one at a time. If no alarms are active, the controller will display **nonE**. See Section 4 – System Operation for alarm pressure thresholds and delays. Alarms will persist until the problem is corrected.

For high pressure safety, the Pressure Control uses unique logic to position the electric valve to a safe position if the valve attempts to reinitialize due to power loss. If this condition exists, the display will read **rE5**. The system will continue to operate; however, the controller will need to be reset at the earliest convenience. To reset the controller, the refrigeration system must be shut down first, and then the power to the Pressure Control must be cycled to allow the electric valve to reinitialize. To avoid this condition, ensure that the power supply to the controller is stable, the power supply wires at the controller are secure and the system controller, or rack controller is configured with a minimum compressor delay of 90 seconds.

Figure 5 - Pressure Sensor Cable

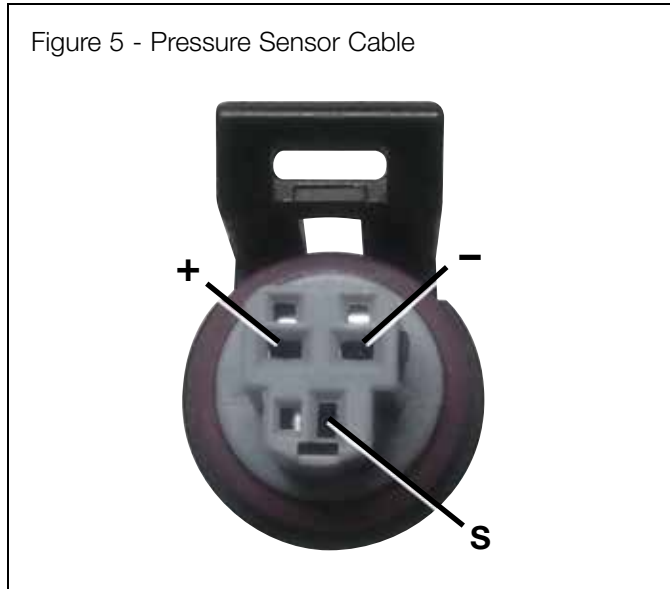

Table 5 - Pressure Transducer Specifications

LABEL COLOR	Prng	PSI
Green	150	(v-.5) x 37.5
None / Silver	300	(v-.5) x 75
Yellow	500	(v-.5) x 125

Table 6 - Alarm Actions

ALARM	DESCRIPTION	ACTION
<b>SEAL</b>	Pressure Sensor Failure	Electric valve is positioned at <b>SEFP</b> (Sensor Error Failsafe Position)
<b>PLAL</b>	Low Pressure	No System Response
<b>PHAL</b>	High Pressure	No System Response
<b>rE5</b>	Reset Alarm	Controller will override current valve position and continue to control (for high pressure safety during valve initialization)
<b>nonE</b>	No Alarm	----

Table 7 - Troubleshooting

SYMPTOM	CHECK
Will not power up	Wiring terminals for power at transformer and controller
	Supply Voltage (See Appendix E, Technical Specifications)
Pressure Below Setpoint	Pressure transducer range (correct transducer range set up in controller; 150, 300, 500 psi)
	Pressure transducer wiring
	Electric Valve (correct valve set up in controller; 2500, 6386 steps, etc)
	Transducer location
	Pressure Rise Valve Direction set correctly
	Minimum and Maximum valve position set correctly
	Electric valve seat leak
	Electric valve wiring connection at controller
Pressure Above Setpoint	Pressure transducer range and type (correct transducer range and type set up in controller; 150A (absolute), 150, 300, 500 psi)
	Pressure transducer wiring
	Transducer location
	Pressure Rise Valve Direction set correctly
	Minimum and Maximum valve position set correctly
	For non-condensables in the system
Display Reads -60.0	Temperature sensor wiring (normal reading if sensors are not installed)
Display Reads <i>rES</i>	Power connections to controller (See discussion on <i>rES</i> in this section)
Pressure Unstable	Condenser fan control (cut-out set above <i>PSP</i> )
	Condenser pressure setpoint (set too close to receiver pressure setpoint)
	Pressure transducer wiring
	Electric pressure regulating valve sizing (oversized)
	Expansion valve sizing (oversized)
	System refrigerant level
	PID setpoints (may be too high)
System High Pressure Limit Met	Power connections to controller
	Stable power supply to controller
	Pressure Rise Valve Direction set correctly
	Maximum valve position set correctly
Valve operates at minimum position	System refrigerant level (too low)
	Electric pressure regulating valve sizing (oversized)
	Condenser pressure setpoint (set too close to receiver pressure setpoint)
High Refrigeration Case Temperature	System refrigerant level
	Pressure Rise Valve Direction set correctly
	Electric pressure regulating valve sizing (undersized)
High Compressor Discharge Temperature	System refrigerant level
	Condenser pressure setpoint (set too close to receiver pressure setpoint)
No Communication	Wiring at controller and master communication board
	Addresses of controllers (see Section 5 – Controller Networking)
Communication Errors	Wiring at controller and master communication board
	Network wiring from controller to master communication board (see Section 5 – Controller Networking)
	Proper network wire grounding (see Section 5 – Controller Networking)
	Network parameters in controller and master communication board (baud rate, parity, etc; see Section 5)
	Third-party controller on control network
Setpoints Not Saved	ESC must be set within 60 seconds of changes being made
Cannot Find Setpoints	See Section 3 – Setpoint Menu Operation

## APPENDIX A - Setup Menu

DISPLAY	DESCRIPTION	OPTIONS
APPL	Control Application	EP <sub>r</sub> Low Side Control
		Co <sub>nd</sub> High Side Condenser Pressure Control
		rEC High Side Receiver Pressure Control
		LP <sub>r</sub> High Side Liquid Pressure Control
P <sub>rn</sub> g	Pressure Transducer Range	150A, 150, 300, 500
PSP	Pressure Setpoint	0 to 90% of selected transducer
StEP	Valve Steps	1596 1596 Bipolar Valve
		3193 3193 Bipolar Valve
		2500 2500 Bipolar Valve
		6386 6386 Bipolar Valve

Default values are highlighted.

## APPENDIX B - Process Values

DISPLAY	DESCRIPTION	RANGE
PrES	Pressure Transducer Input	Depends on pressure transducer range Max: 0 to 500 psig (0 to 34.47 bar)
Posn	Current Valve Position	0 to 100%
StAt	Pumpdown Status	Disabled = d, SA, Enabled = Pd
tCut	Temperature Cut-Out Status	Disabled = d, SA, Enabled = EnAb
AL5	Alarm Status (Lists of all active alarms)	See Table 6
Evout	Evaporator Outlet Temperature Input	-50 to 150°F (-45 to 65°C) for 3K 60 to 299°F (16 to 148°C) for 98.6K
Lout	Liquid Outlet Temperature Input	
Lin	Liquid Inlet Temperature Input	
AuT4	Auxiliary Temperature Input	
SUbc	Subcooling	Depends on refrigerant selected nA when refrigerant is not selected, Evout sensor is not installed or pressure input is not available
SuPH	Superheat	Depends on refrigerant selected nA when refrigerant is not selected, Lout (or Lin) sensor is not installed or pressure input is not available

## APPENDIX C - Setpoint Parameters

PARAMETERS				
Counterclockwise ↑	ESC	Escape and Save Changes	----	
	PSP	Pressure Setpoint	0 to 90% of selected transducer <b>Default is 75 psi (5 bar)</b>	
	APPL	Control Application	Readout	Description
			EP <sub>r</sub> (default)	Low Side Control
			Co <sub>nd</sub>	High Side Condenser Pressure Control
			rEC	High Side Receiver Pressure Control
		LP <sub>r</sub>	High Side Liquid Pressure Control	
	PCAL	Pressure Calibration Offset	-15 to 15 psi <b>Default is 0</b>	
	P <sub>rn</sub> g	Pressure Sensor Range	150 psiA, 150 psi, 300 psi, 500 psi <b>Default is 300</b>	
	StEP	Valve Steps	1596, 3193, 2500, 6386 <b>Default is 2500</b>	
	u.HI	Maximum Valve Position	5% above U.Lo to 100% <b>Default is 100%</b>	
	u.Lo	Minimum Valve Position	0 to 5% below U.HI <b>Default is 0%</b>	
	PSiH	Pressure Input High Alarm Value	0 to 500 psi (Range based on selected pressure transducer) <b>Default is 300</b>	
	PSiL	Pressure Input Low Alarm Value	0 to 500 psi (Range based on selected pressure transducer) <b>Default is 5</b>	
	PSdH	Pressure Alarm Delay High	0 to 60 minutes <b>Default is 1</b>	
PSdL	Pressure Alarm Delay Low	0 to 60 minutes <b>Default is 1</b>		
Un_P	Pressure Units Select PSI or Bar	PSI (PSi) / Bar (bAr) <b>Default is PSI</b>		
			↓ Clockwise	

## APPENDIX C - Setpoint Parameters (continued)

PARAMETERS																																														
<i>Un _t</i>	Temperature Units Select °F or °C	°F ( <i>FAHr</i> ) / °C ( <i>CEL5</i> ) <b>Default is Fahrenheit</b>																																												
<i>PrUd</i>	Pressure Rise Valve Direction	<table border="1"> <tr> <td>Open on Rise (<i>oPPr</i>)</td> <td><i>APPL</i></td> <td><b>Default</b></td> </tr> <tr> <td></td> <td><i>EPr</i></td> <td><i>oPPr</i></td> </tr> <tr> <td>Close on Rise (<i>CLPr</i>)</td> <td><i>Cond</i></td> <td><i>oPPr</i></td> </tr> <tr> <td></td> <td><i>rEc</i></td> <td><i>CLPr</i></td> </tr> <tr> <td></td> <td><i>LPr</i></td> <td><i>CLPr</i></td> </tr> </table>	Open on Rise ( <i>oPPr</i> )	<i>APPL</i>	<b>Default</b>		<i>EPr</i>	<i>oPPr</i>	Close on Rise ( <i>CLPr</i> )	<i>Cond</i>	<i>oPPr</i>		<i>rEc</i>	<i>CLPr</i>		<i>LPr</i>	<i>CLPr</i>																													
Open on Rise ( <i>oPPr</i> )	<i>APPL</i>	<b>Default</b>																																												
	<i>EPr</i>	<i>oPPr</i>																																												
Close on Rise ( <i>CLPr</i> )	<i>Cond</i>	<i>oPPr</i>																																												
	<i>rEc</i>	<i>CLPr</i>																																												
	<i>LPr</i>	<i>CLPr</i>																																												
<i>Pdd</i>	Pumpdown direction	<table border="1"> <tr> <td>Open on Pumpdown (<i>oPPd</i>)</td> <td><i>APPL</i></td> <td><b>Default</b></td> </tr> <tr> <td></td> <td><i>EPd</i></td> <td><i>CLPd</i></td> </tr> <tr> <td>Close on Pumpdown (<i>CLPd</i>)</td> <td><i>Cond</i></td> <td><i>oPPd</i></td> </tr> <tr> <td></td> <td><i>rEc</i></td> <td><i>CLPd</i></td> </tr> <tr> <td></td> <td><i>LPr</i></td> <td><i>oPPd</i></td> </tr> </table>	Open on Pumpdown ( <i>oPPd</i> )	<i>APPL</i>	<b>Default</b>		<i>EPd</i>	<i>CLPd</i>	Close on Pumpdown ( <i>CLPd</i> )	<i>Cond</i>	<i>oPPd</i>		<i>rEc</i>	<i>CLPd</i>		<i>LPr</i>	<i>oPPd</i>																													
Open on Pumpdown ( <i>oPPd</i> )	<i>APPL</i>	<b>Default</b>																																												
	<i>EPd</i>	<i>CLPd</i>																																												
Close on Pumpdown ( <i>CLPd</i> )	<i>Cond</i>	<i>oPPd</i>																																												
	<i>rEc</i>	<i>CLPd</i>																																												
	<i>LPr</i>	<i>oPPd</i>																																												
<i>tCo</i>	Temperature Cut-Out	-60 to 310°F (-51 to 154°C) <b>Default is 310°F (154°C)</b>																																												
<i>SEFP</i>	Sensor Error Failsafe Position	<table border="1"> <tr> <td>Valve position</td> <td><i>APPL</i></td> <td><b>Default</b></td> </tr> <tr> <td>0%</td> <td><i>EPr</i></td> <td>0%</td> </tr> <tr> <td>25%</td> <td><i>Cond</i></td> <td>100%</td> </tr> <tr> <td>50%</td> <td><i>rEc</i></td> <td>0%</td> </tr> <tr> <td>75%</td> <td><i>LPr</i></td> <td>100%</td> </tr> <tr> <td>100%</td> <td></td> <td></td> </tr> </table>	Valve position	<i>APPL</i>	<b>Default</b>	0%	<i>EPr</i>	0%	25%	<i>Cond</i>	100%	50%	<i>rEc</i>	0%	75%	<i>LPr</i>	100%	100%																												
Valve position	<i>APPL</i>	<b>Default</b>																																												
0%	<i>EPr</i>	0%																																												
25%	<i>Cond</i>	100%																																												
50%	<i>rEc</i>	0%																																												
75%	<i>LPr</i>	100%																																												
100%																																														
<i>Ctrl</i>	Auto/Manual PID Control	Auto or PID <b>Default is Auto</b>																																												
<i>-P-</i>	Proportional Coefficient	0 to 100 <b>Default is 4</b>																																												
<i>-I-</i>	Integral Coefficient	0 to 100 <b>Default is 10</b>																																												
<i>-d-</i>	Derivative Coefficient	0 to 100 <b>Default is 2</b>																																												
<i>nEt</i>	Network Type	Modbus ( <i>nbU5</i> ) or BACnet ( <i>bnEt</i> ) <b>Default is Modbus</b>																																												
<i>Addr</i>	Device Address	1 to 247 <b>Default is 1</b>																																												
<i>nPr</i>	Parity Select	None ( <i>nonE</i> ) Even ( <i>EuEn</i> ) <b>Default is Even</b> Odd ( <i>odd</i> )																																												
<i>bAud</i>	RS-485 Bit Rate Selection	9600 ( <i>96</i> ) <b>Default is 9600</b> 19200 ( <i>192</i> ) 38400 ( <i>384</i> )																																												
<i>tSP</i>	Temperature Sensor Type	2K Thermistor ( <i>t52</i> ) 3K Thermistor ( <i>t53</i> ) <b>Default is 3K</b> 98.6K Thermistor ( <i>t598</i> )																																												
<i>SPoS</i>	Manual Valve Position	0% to 100%																																												
<i>rEFr</i>	Refrigerant Type (used only when subcooling or superheat is desired)	<table border="1"> <thead> <tr> <th>Display</th> <th>Refrigerant</th> </tr> </thead> <tbody> <tr><td><i>r22</i></td><td>R-22</td></tr> <tr><td><i>134A</i></td><td>R-134A</td></tr> <tr><td><i>402A</i></td><td>R-402A</td></tr> <tr><td><i>404A</i></td><td>R-404A</td></tr> <tr><td><i>407A</i></td><td>R-407A</td></tr> <tr><td><i>407C</i></td><td>R-407C</td></tr> <tr><td><i>410A</i></td><td>R-410A</td></tr> <tr><td><i>417A</i></td><td>R-417A</td></tr> <tr><td><i>422A</i></td><td>R-422A</td></tr> <tr><td><i>422d</i></td><td>R-422d</td></tr> <tr><td><i>r507</i></td><td>R-507A</td></tr> <tr><td><i>r744</i></td><td>R-744</td></tr> <tr><td><i>245F</i></td><td>245FA</td></tr> <tr><td><i>r-E5</i></td><td>R-E5</td></tr> <tr><td><i>438A</i></td><td>R-438A</td></tr> <tr><td><i>401b</i></td><td>R-401b</td></tr> <tr><td><i>408A</i></td><td>R-408A</td></tr> <tr><td><i>508A</i></td><td>R-508A</td></tr> <tr><td><i>508b</i></td><td>R-508B</td></tr> <tr><td><i>407F</i></td><td>R-407F</td></tr> <tr><td><i>nonE</i></td><td>Not Set</td></tr> </tbody> </table>	Display	Refrigerant	<i>r22</i>	R-22	<i>134A</i>	R-134A	<i>402A</i>	R-402A	<i>404A</i>	R-404A	<i>407A</i>	R-407A	<i>407C</i>	R-407C	<i>410A</i>	R-410A	<i>417A</i>	R-417A	<i>422A</i>	R-422A	<i>422d</i>	R-422d	<i>r507</i>	R-507A	<i>r744</i>	R-744	<i>245F</i>	245FA	<i>r-E5</i>	R-E5	<i>438A</i>	R-438A	<i>401b</i>	R-401b	<i>408A</i>	R-408A	<i>508A</i>	R-508A	<i>508b</i>	R-508B	<i>407F</i>	R-407F	<i>nonE</i>	Not Set
Display	Refrigerant																																													
<i>r22</i>	R-22																																													
<i>134A</i>	R-134A																																													
<i>402A</i>	R-402A																																													
<i>404A</i>	R-404A																																													
<i>407A</i>	R-407A																																													
<i>407C</i>	R-407C																																													
<i>410A</i>	R-410A																																													
<i>417A</i>	R-417A																																													
<i>422A</i>	R-422A																																													
<i>422d</i>	R-422d																																													
<i>r507</i>	R-507A																																													
<i>r744</i>	R-744																																													
<i>245F</i>	245FA																																													
<i>r-E5</i>	R-E5																																													
<i>438A</i>	R-438A																																													
<i>401b</i>	R-401b																																													
<i>408A</i>	R-408A																																													
<i>508A</i>	R-508A																																													
<i>508b</i>	R-508B																																													
<i>407F</i>	R-407F																																													
<i>nonE</i>	Not Set																																													
<i>uEr</i>	Firmware Version	Displays controller firmware version																																												
<i>CDr</i>	Controller Display Address	0 to 99 <b>Default is 0</b>																																												

Counterclockwise

Clockwise

## APPENDIX D - Accessories

DESCRIPTION	ITEM	NOTES
<b>Pressure Control</b>	953474	Standalone Controller with display
<b>Parker Sporlan Temperature Probes</b> 3K Sensor - Brass 98.6K Sensor	952551 952565	Surface or air type High temperature; surface type
<b>Parker Sporlan Pressure Transducers</b> PSPT0500SVSP-S PSPT0300SVSP-S PSPT0150SVSP-S	952576 952574 952572	0-500 psis transducer (R-744 subcritical) 0-300 psis transducer (R-410A) 0-150 psis transducer (all other refrigerants)
<b>Transducer Cables</b> PSPT000000CP50 PSPT000000CP20	953100 953192	5 meter cable 2 meter cable
<b>Troubleshooting Accessories</b> SMA-12	953276	Handheld digital instrument for testing electric valve performance

## APPENDIX E - Technical Specifications

<p><b>ELECTRICAL</b></p> <p><b>Supply Voltage</b> 20-26VAC 50/60Hz or 22-26.6VDC; Class II input</p> <p><b>Digital Inputs</b> 0-5VDC Maximum Range Interface to dry contact or open collector</p> <p><b>Analog Inputs</b> 4 Temperature Sensors (2 Kohm, 3 Kohm, or 98.6 Kohm)  1 Pressure Transducer .5 - 4.5VR (150 psiA, 150 psig, 300 psig, or 500 psig)</p> <p><b>Relay Outputs</b> 100-240VAC, 3A ind/250V 22-28VDC, 250mA digital output w/ground (Not currently used)</p> <p><b>Digital Display</b> LED - Red, 7 segment, 4 digit</p> <p><b>Indicators</b> LED - Red, Power</p> <p><b>User Interface</b> Optical Encoder (SELECT knob)</p> <p><b>Data Interface</b> RS485, Modbus</p>	<p><b>MECHANICAL</b></p> <p><b>Operating Temperature</b> -40°F to 158°F (-40°C to 70°C)</p> <p><b>Humidity</b> 0-95%RH (Non-Condensing)</p> <p><b>Enclosure</b> PC - Light Gray</p> <p><b>Wiring</b> Screw terminal, 12-24 AWG</p> <p><b>Mounting</b> DIN Rail - EN 50 022</p> <p><b>COMPLIANCE</b></p> <p><b>Environmental</b> RoHS WEEE</p> <p><b>Electrical</b> CE UL/CUL (Recognized per 873)  FCC (Class A, part 15) C-tick</p>
---	--

# APPENDIX F - Wiring Diagram and System Schematic

## WIRING DIAGRAM

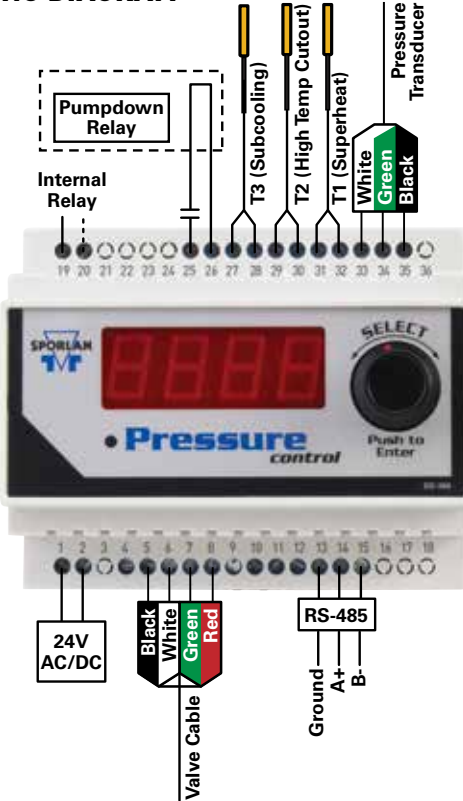

## SYSTEM SCHEMATIC EXAMPLE

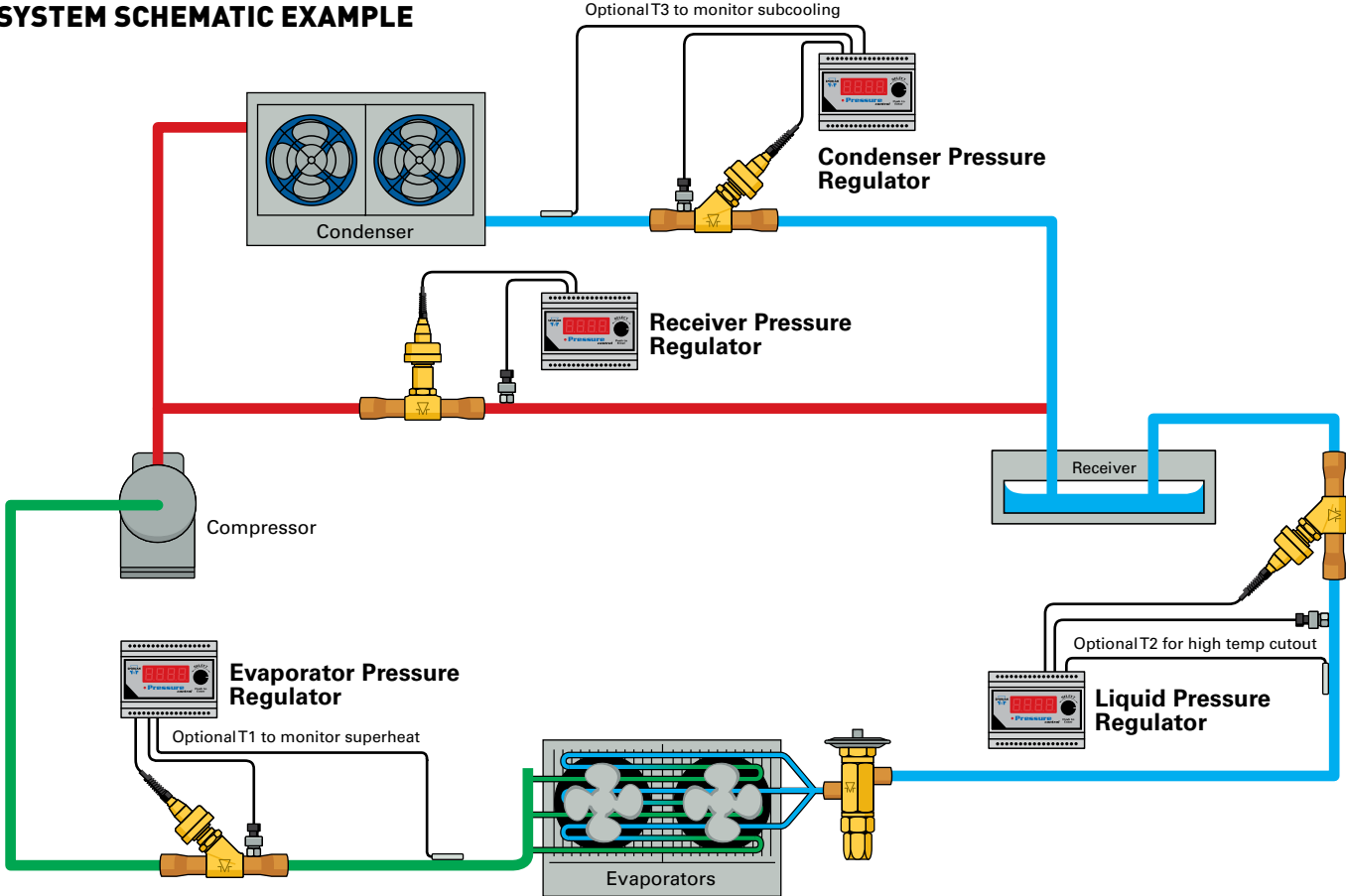

 **NOTE:** Use caution when working around high voltage components.

**APPENDIX G - Modbus Memory Map**

MODBUS FUNCTION CODE	DATA TYPE	DATA MAP	RANGE	
Read Coils (0x01) Read Holding Registers (0x03)	Status	Manual Valve Control	0 = Disabled 1 = Enabled	
		Pumpdown	0 = Disabled 1 = Enabled	
		Temp Cutout	0 = Disabled 1 = Enabled	
	Setpoints	Pressure Setpoint		0 to 500 (34.47 bar)
		Control Application		0 = EPR 1 = COND 2 = REC 3 = LPR
		Pressure Calibration Offset		-15 to +15 PSI
		Pressure Transducer Range		0 = 150 PSIA 1 = 150 PSIG 2 = 300 PSIG 3 = 500 PSIG
		Valve Steps		0 = 1596 1 = 3193 2 = 2500 3 = 6386
		Maximum Valve Position		5% above Minimum Valve Position to 100%
		Minimum Valve Position		0 to 5% below Maximum Valve Position
		PSI High Alarm Value		0 to 500 (34.47 bar)
		PSI Low Alarm Value		0 to 500 (34.47 bar)
		PSI High Pressure Alarm Delay		0-60 minutes
		PSI Low Pressure Alarm Delay		0-60 minutes
		Temperature Unit Select		0 = °F 1 = °C
		Pressure Rise Valve Direction ( <i>PrUd</i> )		0 = Open on Pressure Rise 1 = Close on Pressure Rise
		Pumpdown Direction ( <i>Pdd</i> )		0 = Open on Pumpdown 1 = Close on Pumpdown
		Temperature Cut – Out ( <i>tCo</i> )		-60°F to 310°F (-51°C to 154°C)
		Sensor Error Failsafe Position ( <i>SEFP</i> )		0 = 0% on sensor error 1 = 25% on sensor error 2 = 50% on sensor error 3 = 75% on sensor error 4 = 100% on sensor error
		Auto/Man PID Control ( <i>Ctrl</i> )		0 = Automatic 1 = Manual
		Proportional Coefficient		0-100
		Integral Coefficient		0-100
		Derivative Coefficient		0-100
		Device MODBUS Address		1-247
		Temperature Sensor Type		0 = 2K 1 = 3K 2 = 98.6K
		Manual Valve Position		0.0-100.0%
		Password Write		0 to 999



**APPENDIX G - Modbus Memory Map (continued)**

MODBUS FUNCTION CODE	DATA TYPE	DATA MAP	RANGE																																												
Read Coils (0x01) Read Holding Registers (0x03)	Setpoints	Refrigerant Type	<table border="1"> <thead> <tr> <th>Value</th> <th>Refrigerant</th> </tr> </thead> <tbody> <tr><td>0</td><td>R-22</td></tr> <tr><td>1</td><td>R-134A</td></tr> <tr><td>2</td><td>R-402A</td></tr> <tr><td>3</td><td>R-404A</td></tr> <tr><td>4</td><td>R-407A</td></tr> <tr><td>5</td><td>R-407C</td></tr> <tr><td>6</td><td>R-410A</td></tr> <tr><td>7</td><td>R-417A</td></tr> <tr><td>8</td><td>R-422A</td></tr> <tr><td>9</td><td>R-422d</td></tr> <tr><td>10</td><td>R-507A</td></tr> <tr><td>11</td><td>R-744</td></tr> <tr><td>12</td><td>245FA</td></tr> <tr><td>13</td><td>R-E5</td></tr> <tr><td>14</td><td>R-438A</td></tr> <tr><td>15</td><td>R-401b</td></tr> <tr><td>16</td><td>R-408A</td></tr> <tr><td>17</td><td>R-508A</td></tr> <tr><td>18</td><td>R-508B</td></tr> <tr><td>19</td><td>R-407F</td></tr> <tr><td>20</td><td>Not Set</td></tr> </tbody> </table>	Value	Refrigerant	0	R-22	1	R-134A	2	R-402A	3	R-404A	4	R-407A	5	R-407C	6	R-410A	7	R-417A	8	R-422A	9	R-422d	10	R-507A	11	R-744	12	245FA	13	R-E5	14	R-438A	15	R-401b	16	R-408A	17	R-508A	18	R-508B	19	R-407F	20	Not Set
			Value	Refrigerant																																											
0	R-22																																														
1	R-134A																																														
2	R-402A																																														
3	R-404A																																														
4	R-407A																																														
5	R-407C																																														
6	R-410A																																														
7	R-417A																																														
8	R-422A																																														
9	R-422d																																														
10	R-507A																																														
11	R-744																																														
12	245FA																																														
13	R-E5																																														
14	R-438A																																														
15	R-401b																																														
16	R-408A																																														
17	R-508A																																														
18	R-508B																																														
19	R-407F																																														
20	Not Set																																														
		Pressure Unit Select	0 = PSI 1 = Bar																																												
Read Input Registers (0x04)	Process Variables	Pressure	0 to 500 PSI (0 to 34.47 bar)																																												
		Valve Position	0.0 to 100.0% open																																												
		T1	-60°F to 299°F (-51°C to 148°C)																																												
		T2	-60°F to 299°F (-51°C to 148°C)																																												
		T3	-60°F to 299°F (-51°C to 148°C)																																												
		T4	-60°F to 299°F (-51°C to 148°C)																																												
		Relay Status	0 = De-energized 1 = Energized																																												
		Alarm Status Byte	Bit 0 = Press Alarm High Bit 1 = Press Alarm Low Bit 2 = Pressure Sensor Alarm Bit 3 = Reset Alarm Active (1 = Alarm Active)																																												
		Firmware Revision	0 to 65535																																												
Subcooling	0°F to 150°F (-17.8°C to 65.6°C)																																														
Superheat	0°F to 150°F																																														
Write Single Coil (0x05)	Manual Valve Control	Manual Valve Enabled Flag	0 = Disabled 1 = Enabled																																												
	Pumpdown Control	Pumpdown Enabled Flag	0 = Disabled 1 = Pumpdown Enabled																																												
Write Single Register (0x06)	Setpoints	Same as 'Read Holding Register' Definitions	Selected Register to Write																																												
	Password	User Password	Enables parameter modification																																												

## APPENDIX H - BACnet Memory Map

### DEVICE OBJECT

OBJECT INSTANCE	OBJECT NAME	WRITEABLE PROPERTY RANGES	OPTIONAL PROPERTIES SUPPORTED
<Controller Address>	"PRESSURE_CONTROLLER-###" where "###" is the controller address. Ex. "PRESSURE_CONTROLLER-001" for controller address 1	None	None

Device Property Description	Default Value
Vendor Name	"Parker Hannifin"
Vendor Identifier	287
Model Name	"KELVIN II - 4TEMP"
Firmware Revision	Latest Revision formatted as <Major Version> '.' <Minor Version>
Application Software Version	Firmware Date formatted as <Month> '/' <Day> '/' <Year>
Protocol Version	Latest Protocol Version Supported
Protocol Revision	Latest Protocol Revision Supported
Protocol Services Supported	Read Property Write Property Who-Is I-Am
Object Types Supported	Analog Input Object Analog Value Object Binary Output Object Binary Value Object Device Object Loop Object Multistate Value Object
Maximum APDU Size	480
Segmentation Support	Segmentation Not Supported
APDU Timeout	3 seconds
Number of APDU Retries	1
Database Revision	Latest Database Revision

### ANALOG INPUT OBJECTS

OBJECT INSTANCE	OBJECT NAME	WRITEABLE PROPERTY RANGES	OPTIONAL PROPERTIES SUPPORTED
1	"PRESSURE"	None	None
2	"TEMPERATURE-1"		
3	"TEMPERATURE-2"		
4	"TEMPERATURE-3"		
5	"TEMPERATURE-4"		

## APPENDIX H - BACnet Memory Map (continued)

### ANALOG VALUE OBJECTS

OBJECT INSTANCE	OBJECT NAME	WRITEABLE PROPERTY RANGES	OPTIONAL PROPERTIES SUPPORTED
		PRESENT VALUE	
1	"PRESSURE_SP"	0 to 500 PSI (0 to 34.47 bar)	None
2	"PRESSURE_OFFSET"	-15 to +15 PSI	
3	"MAXIMUM_VALVE_POSITION"	5% above "MINIMUM_VALVE_POSITION" to 100%	
4	"MINIMUM_VALVE_POSITION"	0 to 5% below "MAXIMUM_VALVE_POSITION"	
5	"PRESSURE_HIGH_ALARM_VALUE"	0 to 500 PSI (0 to 34.47 bar)	
6	"PRESSURE_LOW_ALARM_VALUE"	0 to 500 PSI (0 to 34.47 bar)	
7	"HIGH_PRESSURE_ALARM_DELAY"	0 to 60 minutes	
8	"LOW_PRESSURE_ALARM_DELAY"	0 to 60 minutes	
9	"TEMPERATURE_CUTOUT"	-60°F to 310°F (-51°C to 154°C)	
10	"MANUAL_VALVE_POSITION"	0 to 100%	
11	"CURRENT_VALVE_POSITION"	0 to 100%	
12	"SUBCOOLING"	Not Writeable	
13	"SUPERHEAT"	Not Writeable	

### BINARY OUTPUT OBJECTS

OBJECT INSTANCE	OBJECT NAME	WRITEABLE PROPERTY RANGES	OPTIONAL PROPERTIES SUPPORTED
		PRESENT VALUE	
1	"RELAY-1"	INACTIVE = "DE-ENERGIZED" ACTIVE = "ENERGIZED"	Inactive Text Active Text

### BINARY VALUE OBJECTS

OBJECT INSTANCE	OBJECT NAME	WRITEABLE PROPERTY RANGES	OPTIONAL PROPERTIES SUPPORTED
		PRESENT VALUE	
1	"MANUAL_VALVE_CONTROL"	INACTIVE = "DISABLED" ACTIVE = "ENABLED"	Inactive Text Active Text
2	"TEMP_CUTOUT_STATUS"	INACTIVE = "DISABLED" ACTIVE = "ENABLED"	
3	"PRESSURE_RISE_VALVE_DIRECTION"	INACTIVE = "OPEN ON PRESSURE RISE" ACTIVE = "CLOSE ON PRESSURE RISE"	
4	"PUMPDOWN_DIRECTION"	INACTIVE = "OPEN ON PUMPDOWN" ACTIVE = "CLOSE ON PUMPDOWN"	
5	"MANUAL_OR_AUTO_PID_CONTROL"	INACTIVE = "AUTOMATIC" ACTIVE = "MANUAL"	
6	"PRESSURE_ALARM_HIGH"	INACTIVE = "INACTIVE" ACTIVE = "ACTIVE"	
7	"PRESSURE_ALARM_LOW"	INACTIVE = "INACTIVE" ACTIVE = "ACTIVE"	
8	"PUMPDOWN_STATUS"	INACTIVE = "DISABLED" ACTIVE = "ENABLED"	
9	"RESET_ALARM"	INACTIVE = "INACTIVE" ACTIVE = "ACTIVE"	

### LOOP OBJECTS

OBJECT INSTANCE	OBJECT NAME	WRITEABLE PROPERTY RANGES						OPTIONAL PROPERTIES SUPPORTED
		Present Value	Proportional Constant	Integral Constant	Derivative Constant	Maximum Output	Minimum Output	
1	"PRESSURE_CONTROL_LOOP"	0 to 100%	0 to 100	0 to 100	0 to 100	1 to 100%	0 to 20%	None

**APPENDIX H - BACnet Memory Map (continued)****MULTISTATE VALUE OBJECTS**

OBJECT INSTANCE	OBJECT NAME	WRITEABLE PROPERTY RANGES	OPTIONAL PROPERTIES SUPPORTED
		Present Value	
1	"PRESSURE_TRANSDUCER_RANGE"	1 = 150 PSIA 3 = 300 PSIG 2 = 150 PSIG 4 = 500 PSIG	State Text
2	"VALVE_STEPS"	1 = 1596 3 = 2500 2 = 3193 4 = 6386	
3	"SENSOR_ERROR_FAILSAFE_POSITION"	1 = 0% on sensor error 4 = 75% on sensor error 2 = 25% on sensor error 5 = 100% on sensor error 3 = 50% on sensor error	
4	"TEMPERATURE_SENSOR_TYPE"	1 = 2K 2 = 3K 3 = 98.6K	
5	"TEMPERATURE_UNITS"	1 = Degrees F 2 = Degrees C	
6	"CONTROLLER_ADDRESS"	1 to 247	None
7	"PASSWORD_WRITE"	0 to 999	
8	"CONTROL_APPLICATION"	1 = EPR 2 = COND 3 = REC 4 = LPR	State Text
9	"REFRIGERANT"	1 = R22 7 = R410A 13 = 245FA 19 = R508B 2 = R134A 8 = R417A 14 = R-E5 20 = R407F 3 = R402A 9 = R422A 15 = R438A 21 = None 4 = R404A 10 = R422d 16 = R401b 5 = R407A 11 = R507A 17 = R408A 6 = R407C 12 = R744 18 = R508A	State Text
10	"PRESSURE_UNITS"	1 = PSI 2 = Bar	State Text

**APPENDIX I - Temperature Sensor Specifications**

TEMPERATURE		VDC		
°F	°C	2K	3K	98.6K
-50	-45.6	4.301	4.773	---
-40	-40.0	4.105	4.676	---
-30	-34.4	3.877	4.547	---
-20	-28.9	3.621	4.382	---
-10	-23.3	3.343	4.176	---
0	-17.8	3.050	3.929	---
10	-12.2	2.751	3.643	---
20	-6.7	2.455	3.326	---
30	-1.1	2.170	2.988	---
40	4.4	1.902	2.644	---
50	10.0	1.656	2.306	4.83
60	15.6	1.434	1.985	4.78
70	21.1	1.237	1.691	4.72
80	26.7	1.064	1.428	4.65
90	32.2	0.914	1.198	4.56
100	37.8	0.785	1.002	4.45
110	43.3	0.674	0.835	4.33
120	48.9	0.580	0.696	4.19

TEMPERATURE		VDC		
°F	°C	2K	3K	98.6K
130	54.4	0.500	0.579	4.04
140	60.0	0.431	0.483	3.87
150	65.6	0.373	0.404	3.68
160	71.1	---	---	3.48
170	76.7	---	---	3.27
180	82.2	---	---	3.06
190	87.8	---	---	2.84
200	93.3	---	---	2.62
210	98.9	---	---	2.41
220	104.4	---	---	2.20
230	110.0	---	---	2.01
240	115.6	---	---	1.82
250	121.1	---	---	1.65
260	126.7	---	---	1.48
270	132.2	---	---	1.34
280	137.8	---	---	1.20
290	143.3	---	---	1.08
300	148.9	---	---	0.97

