



Step Motor Expansion Valves

Type SEHI-175, -P, -400 and -T

Installation and Servicing Instructions for Flammable Refrigerants
SD-425/022018



The Sporlan SEHI valves are stepper motor driven Electric Expansion Valves (EEV), featuring:

- High resolution actuators
- High linear force output
- Exceptional flow control across widely varying conditions
- Tight seating
- Bi-directional flow capability
- Field proven reliability
- Serviceable motor assemblies
- Hermetic cable design
- 12VDC (Pulsed Signal)

APPLICATION

- The above EEV valves are designed for use with A2L and A3 (flammable) refrigerants such as HFO and Hydrocarbons.
- Classified in accordance with the European Directives (2014/68/EU) “Pressure Equipment Directive” and (2014/34/EU) “ATEX Directive” concerning equipment intended for use in potentially explosive atmospheres.
 - Ex II 3 G Ex nA IIC T6 Gc $-20^{\circ}\text{C} \leq \text{Ta} \leq +60^{\circ}\text{C}$ IP64/67
 - ATEX Certification Number ITS16ATEX400995X
- The intended design life of the Electric Expansion Valve is 15 years, providing that the valve is installed and operated within the design intent, and the system is free from contaminants. The intended life expectancy is not to be construed or used as a Parker Hannifin warranty. The Parker Hannifin User Responsibility Statement and Offer of Sale specify terms and conditions, including the standard product warranty and liability.

SPECIAL CONDITIONS OF USE and SAFETY **WARNING!**

All electrical equipment must be suitably certified for its intended hazardous location and installed/inspected in accordance with the latest edition of Standards: EN 60079-0:2012 + A11: 2013, EN 60079-15:2010, EN 13463-1: 2009 and EN 1127-1: 2011.

- To avoid electrostatic charging and/or electrical shock, steps must be taken to ensure equipotential bonding is maintained through all isolated parts, and the equipment is earth bonded via the valve’s connections. Isolation of conductive parts will cause an ignition hazard. Power shall not be applied to the valve until adequate ground bonding is maintained.
- The valve must be protected from external impact that may cause a spark.
- Personnel handling or working on or with this product must be qualified for that task. In an ATEX zone, the personnel must be educated in the risks of explosion.
- It is the responsibility of the Installer to check that there is no leakage after installation, especially in case of potentially explosive atmospheres.
- The valve and its control must not undergo any modification without prior approval from the equipment manufacturer or Parker Hannifin -- Sporlan Division.
- Sporlan is not responsible for any damage which may be caused by misuse or by installation of parts, accessories or controls which are not on the original specification.
- Hot or cold parts of the valve which present a danger to the operator must be protected.

MAINTAINANCE, INSTALLATION and SERVICE

- Only authorized persons who are certified in installing and maintaining refrigeration and air conditioning systems containing flammable refrigerants may do the installation and maintenance.
- All local requirements or codes regarding use of flammable refrigerants in refrigeration and air conditioning systems must be followed.
- The refrigeration or air conditioning system must be designed so no abnormal impact (e.g. vibration, liquid hammer, pressure pulsations) can create risk for damage to the system.
- When replacing parts, only use identical replacement parts, or previously authorized substitutes.
- Parker Hannifin – Sporlan Division takes no responsibility for the classification of the refrigeration and/or air conditioning system.

NEW INSTALLATION STEPS

1. Braze or solder the inlet and outlet connections using standard practices and materials. Care should be taken to avoid melting or damaging the valve cable. See Figure 1. During installation the cable should be routed to avoid direct or indirect damage from overheating.

NOTE: Care must be taken to ensure that the valve internal temperature does not reach 60°C (250°F).

2. Wire the valve cable to the controller according to the controller specifications. The required valve drive sequence is shown here for reference.

BIPOLAR DRIVE SEQUENCE				
Step	Black	White	Red	Green
1	12 volts	0 volts	12 volts	0 volts
2	0 volts	12 volts	12 volts	0 volts
3	0 volts	12 volts	0 volts	12 volts
4	12 volts	0 volts	0 volts	12 volts
1	12 volts	0 volts	12 volts	0 volts

↑ OPEN ↓ ↓ CLOSE ↑

3. Apply power to the valve controller. The valve is shipped at approximately half stroke, so the controller will overdrive closed to establish the zero position. A light clicking may be heard during this time. Upon completion of initialization, the valve should be ready to begin controlling.

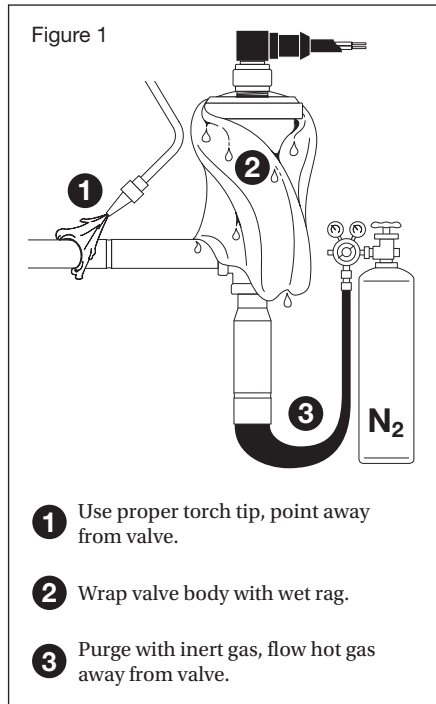

FIELD SERVICE INSTRUCTIONS

1. If the valve fails to operate properly, disconnect the line voltage from the valve controller. Disconnect the valve leads from the controller.
2. Check the resistance of each motor phase. The resistance between either the black and white or red and green leads should be approximately 75Ω at 22°C (72°F). Differences of more than 10% between phases may indicate a defective motor, and the motor adapter assembly should be replaced.
3. Check to ensure that resistance between any lead and the valve body is greater than $1\text{M}\Omega$. Lower resistance readings may indicate a short, and the motor adapter assembly should be replaced.
4. If you have access to a Sporlan SMA-12 test instrument, functionality of the valve can be determined before removal from the system by monitoring changes in system conditions as valve position is changed, or by visually verifying piston movement in the sight glass. If normal function can be verified by manually positioning the valve, proper controller functionality should be investigated.

NOTE: Care should be taken to assure that damage to the system does not occur during a manual positioning test due to an improperly positioned valve.

5. Prior to removing a valve or motor adapter assembly, make sure the refrigerant has been properly recovered and pressure has been reduced to a safe level (0 psig).

WARNING: The area should be vented thoroughly to prevent accumulation of flammable vapor.

6. Using an SMA-12 or the manual positioning capability of the valve controller, retract the piston (open the valve).

NOTE: Removing the motor adapter assembly with the piston fully extended (valve closed) may cause permanent damage to the piston assembly.

7. Refer to the exploded view of the valve prior to disassembly. Using a wrench or fixture to support the valve body, remove the motor adapter assembly.

8. If you have access to a Sporlan SMA-12 test instrument, functionality of the valve can be visually confirmed by watching the piston extend and retract.

NOTE: Be careful when extending the valve piston to avoid accidentally driving the piston out of the adapter housing. If removed, extreme care should be taken to ensure that the piston seal is not damaged during reinstallation of the piston.

9. The original or a replacement motor adapter assembly can be reinstalled into the existing valve body. Lightly oil the gasket and thread the motor adapter assembly into the valve body. Tighten the adapter to a torque of 30-35 ft-lb.

NOTE: If the piston is extended while the motor adapter assembly is removed from the valve, it must be retracted prior to reinstalling in the system. Failure to retract the piston (open the valve) prior to installation may cause permanent damage to the piston assembly.

NOTE: Service kits are shipped at approximately half stroke and do not need to be moved prior to installation.

10. Pressurize the system and check for leaks.

NOTE: It is the responsibility of the Installer to check that there is no leakage after installation, especially in case of potentially explosive atmospheres.

11. Reconnect the cable to the controller according to the controller specifications and reapply power. The valve will initialize and then resume normal operation.

SEH MOTOR AND ADAPTER ASSEMBLY

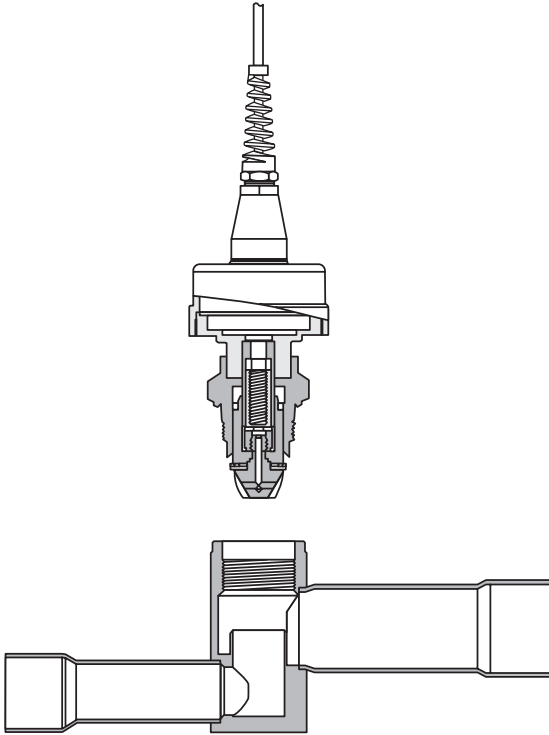

⚠ WARNING! – USER RESPONSIBILITY

Failure or improper selection or improper use of the products described herein or related items can cause death, personal injury and property damage.

This document and other information from Parker Hannifin Corporation, its subsidiaries and authorized distributors provide product or system options for further investigation by users having technical expertise.

The user, through its own analysis and testing, is solely responsible for making the final selection of the system and components and assuring that all performance, endurance, maintenance, safety and warning requirements of the application are met. The user must analyze all aspects of the application, follow applicable industry standards, and follow the information concerning the product in the current product catalog and in any other materials provided from Parker or its subsidiaries or authorized distributors.

To the extent that Parker or its subsidiaries or authorized distributors provide component or system options based upon data or specifications provided by the user, the user is responsible for determining that such data and specifications are suitable and sufficient for all applications and reasonably foreseeable uses of the components or systems.

FOR USE ON REFRIGERATION and/or AIR CONDITIONING SYSTEMS ONLY

