



Pulse Width Modulation Valves

Models SPW-0 thru -7

SPORLAN



ENGINEERING YOUR SUCCESS.



Features and Benefits

Pulse Width Modulation Valves (SPW)

- Controls refrigerant by cycling on/off during 6 second period
- Designed for HFC, HCFC and HFO (non-flammable & non-toxic) System Operation
- Operates from 10% to 100% of rated capacity
- Tight seating design
- Robust Design, 50 Million+ Cycle Life
- Low Wattage NEMA-4X Coil, IP65 Rated, Class F
- Brass, Copper & Stainless Steel Design for Premier Corrosion Resistance
- Serviceable Design with Interchangeable Port & Strainer
- Maximum Rated Pressure (MRP) 1305 psig / 90 barg
- Maximum Operating Pressure Differential (MOPD) 507 psid / 35 bar

Pulse Width Modulation Valves

For Refrigerant Flow Control in Direct Expansion HFC, HCFC and HFO Refrigeration Systems

The Sporlan SPW line of electric expansion valves uses pulse width modulation (PWM) control to manage refrigerant flow in direct expansion HFC, HCFC and HFO (non-flammable & non-toxic) refrigeration systems. The valve's duty cycle is varied based on measured evaporator superheat. Typical controllers monitor superheat and vary the duty cycle across a 6 second period.

Sporlan's Pulse Width Modulation Valves are rated at 100% duty cycle, no reserve capacity. Pulse Width Modulation Valves are typically sized between 50% and 85% duty cycle. This allows additional capacity for pulldown at start-up and after defrost. Further consideration should be given to the liquid line size to avoid excessive liquid hammer. Liquid line velocity should not exceed 3 ft/second.

The SPW valve family offers 8 port sizes to cover a wide range of evaporator loads. The serviceable port and strainer design allows the contractor to service and clean the SPW valve or easily replace the port during a refrigerant retrofit.

The SPW Valve line is rated for a Maximum Rated Pressure (MRP) of 1305 psig (90 barg). The Maximum Operating Pressure Differential (MOPD) is 507 psid (35 bar). Solenoid coils are available for 24 VAC/60 Hz, 110-120 VAC / 50-60 Hz and 220-240 VAC / 50-60 Hz.

Dimensions

Figure 1

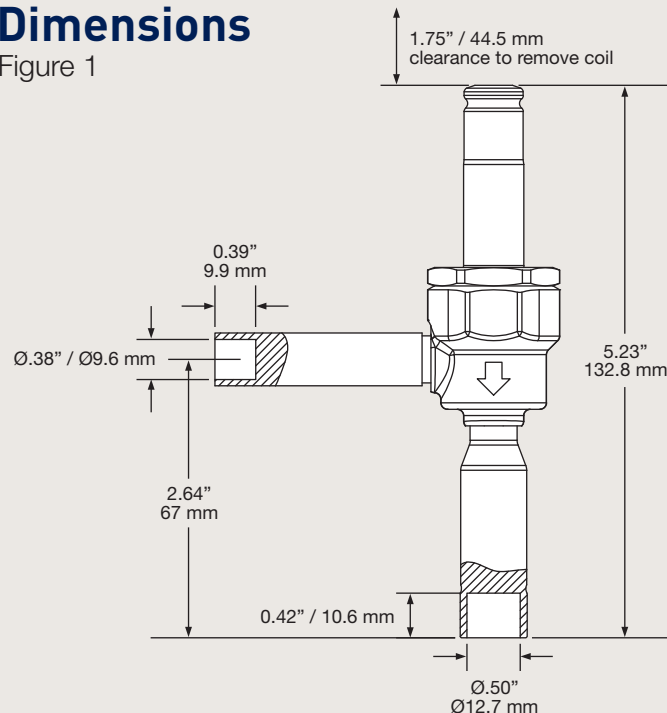

Specifications

SPW Valve Family General Specifications

Actuation Type	Pulse Width Modulation
Recommended Period	6 seconds
Control Range	10 – 100% Duty Cycle
Voltage	24 VAC/60 Hz 110-120 VAC/50-60 Hz 220-240 VAC/50-60 Hz
Power Input (Watts)	11W
Inrush (VA)	38 VA
Holding Power (VA)	22 VA
Coil Resistance (ohms)	4.0 Ω (24 VAC) 103.1 Ω (110-120 VAC) 412.9 Ω (220-240 VAC)
Electrical Connection Style	½" NPT Conduit W/18" leads DIN 43650A
Flow Direction	Side Inlet, Bottom Outlet
Mounting Orientation	Enclosing Tube No Less than Horizontal
Serviceability	Coil, Port and Strainer
Strainer Size (micron)	100
Approved Refrigerant (Class A1)	HFC, HCFC, HFO (non-toxic & non-flammable), CO ₂ Approval Pending
Approved Refrigerant Oil	POE, PAG, PVE, Mineral
Max Internal Leak (sccm Air)	5 @ 100 psid
Max External Leak (sccm Helium)	0.1 oz/year @ 300 psig
Certifications & Compliance	UL File MH4576, PED, Reach, ROHS, LVD

APPLICATION LIMITATIONS	MAXIMUM	MINIMUM
Ambient temperature	130°F (54°C)	-40°F (-40°C)
Fluid temperature	180°F (82°C)	-40°F (-40°C)
Installation Temperature	250°F, 15 minutes maximum	
Relative Ambient Humidity	95% Non-condensing (IP65 Rated)	
Maximum Rated Pressure (MRP)*	1305 psig (90 barg)	
Pressure Differential (MOPD)	507 psid (35 bar)	

*Maximum Rated Pressure for stand still conditions. Liquid must be present at valve inlet for operation.

Capacity - Tons

R-744 Capacities in Tons (at Evaporator Temperature ° F)

Valve Type	20°F													0°F													-20°F													-40°F												
	Pressure Drop Across Valve (psid)													Pressure Drop Across Valve (psid)													Pressure Drop Across Valve (psid)													Pressure Drop Across Valve (psid)												
	100	150	200	250	300	350	400	450	100	150	200	250	300	350	400	450	100	150	200	250	300	350	400	450	100	150	200	250	300	350	400	450																				
R-744 SPW-0																																																				
SPW-1																																																				
SPW-2																																																				
SPW-3																																																				
SPW-4																																																				
SPW-5																																																				
SPW-6																																																				
SPW-7																																																				

CO₂ APPROVAL PENDING

R-134a Capacities in Tons (at Evaporator Temperature ° F)

Valve Type	40°F													20°F													0°F												
	Pressure Drop Across Valve (psid)													Pressure Drop Across Valve (psid)													Pressure Drop Across Valve (psid)												
	40	60	80	100	120	140	160	180	40	60	80	100	120	140	160	180	40	60	80	100	120	140	160	180	40	60	80	100	120	140	160	180							
R-134a SPW-0	0.06	0.07	0.08	0.09	0.10	0.11	0.12	0.12	0.06	0.07	0.08	0.09	0.10	0.10	0.11	0.12	0.05	0.06	0.07	0.08	0.09	0.10	0.11	0.11	0.08	0.09	0.10	0.11	0.12	0.13	0.14	0.15							
SPW-1	0.14	0.17	0.20	0.22	0.25	0.27	0.28	0.30	0.14	0.17	0.19	0.21	0.23	0.25	0.27	0.29	0.13	0.16	0.18	0.20	0.22	0.24	0.26	0.27	0.25	0.28	0.30	0.32	0.34	0.36	0.38	0.40							
SPW-2	0.25	0.31	0.36	0.40	0.44	0.48	0.51	0.54	0.24	0.30	0.34	0.38	0.42	0.45	0.49	0.52	0.23	0.28	0.33	0.36	0.40	0.43	0.46	0.49	0.47	0.51	0.55	0.59	0.63	0.67	0.71	0.76							
SPW-3	0.39	0.48	0.56	0.62	0.68	0.74	0.79	0.83	0.37	0.46	0.53	0.59	0.65	0.70	0.75	0.80	0.36	0.44	0.50	0.56	0.62	0.67	0.71	0.76	0.74	0.80	0.86	0.92	0.97	1.02	1.07	1.12							
SPW-4	0.68	0.83	0.96	1.08	1.18	1.27	1.36	1.44	0.65	0.79	0.92	1.03	1.12	1.21	1.30	1.38	0.62	0.75	0.87	0.97	1.07	1.15	1.23	1.31	1.29	1.38	1.46	1.54	1.62	1.70	1.78	1.86							
SPW-5	1.07	1.31	1.51	1.69	1.85	2.00	2.14	2.27	1.02	1.25	1.44	1.61	1.77	1.91	2.04	2.16	0.97	1.19	1.37	1.53	1.68	1.81	1.94	2.06	2.04	2.14	2.23	2.32	2.41	2.50	2.58	2.66							
SPW-6	1.80	2.20	2.54	2.84	3.11	3.36	3.60	3.81	1.71	2.10	2.42	2.71	2.97	3.21	3.43	3.64	1.63	2.00	2.30	2.58	2.82	3.05	3.26	3.46	3.44	3.54	3.63	3.72	3.81	3.90	3.99	4.08							
SPW-7	3.16	3.87	4.47	5.00	5.48	5.91	6.32	6.71	3.01	3.69	4.26	4.77	5.22	5.64	6.03	6.40	2.87	3.51	4.05	4.53	4.96	5.36	5.73	6.08	6.06	6.16	6.25	6.34	6.43	6.52	6.61	6.70							

R-22 and R-407F Capacities in Tons (at Evaporator Temperature ° F)

Valve Type	40°F													20°F													0°F													-20°F												
	Pressure Drop Across Valve (psid)													Pressure Drop Across Valve (psid)													Pressure Drop Across Valve (psid)													Pressure Drop Across Valve (psid)												
	75	100	125	150	175	200	225	250	275	300	325	350	375	400	75	100	125	150	175	200	225	250	275	300	325	350	375	400	75	100	125	150	175	200	225	250																
R-22 & R-407F SPW-0	0.09	0.10	0.11	0.12	0.13	0.14	0.15	0.16	0.08	0.10	0.11	0.12	0.13	0.14	0.15	0.08	0.09	0.10	0.11	0.12	0.13	0.14	0.15	0.08	0.09	0.10	0.11	0.12	0.13	0.14	0.15	0.08	0.09	0.10	0.11	0.12	0.13	0.14	0.15													
SPW-1	0.21	0.24	0.27	0.29	0.32	0.34	0.36	0.38	0.20	0.23	0.26	0.29	0.31	0.33	0.37	0.40	0.23	0.25	0.28	0.30	0.32	0.34	0.36	0.19	0.22	0.25	0.27	0.29	0.31	0.33	0.35	0.33	0.35	0.37	0.39	0.41	0.43	0.45														
SPW-2	0.37	0.43	0.48	0.53	0.57	0.61	0.65	0.68	0.36	0.42	0.47	0.52	0.56	0.59	0.63	0.66	0.35	0.41	0.46	0.50	0.54	0.58	0.61	0.65	0.34	0.40	0.44	0.48	0.52	0.56	0.59	0.63	0.61	0.65	0.69	0.73	0.77	0.81														
SPW-3	0.58	0.67	0.74	0.82	0.88	0.94	1.00	1.05	0.56	0.65	0.73	0.80	0.86	0.92	0.97	1.03	0.55	0.63	0.71	0.77	0.83	0.89	0.95	1.00	0.53	0.61	0.68	0.75	0.81	0.86	0.92	0.97	1.03	1.08	1.14	1.19	1.25															
SPW-4	1.00	1.15	1.29	1.41	1.52	1.63	1.73	1.82	0.97	1.12	1.26	1.38	1.49	1.59	1.69	1.78	0.95	1.09	1.22	1.34	1.44	1.54	1.64	1.73	0.92	1.06	1.18	1.29	1.40	1.49	1.58	1.67	1.76	1.85	1.94	2.03	2.12															
SPW-5	1.57	1.81	2.03	2.22	2.40	2.56	2.72	2.87	1.53	1.77	1.98	2.16	2.34	2.50	2.65	2.79	1.49	1.72	1.92	2.10	2.27	2.43	2.58	2.71	1.44	1.66	1.86	2.04	2.20	2.35	2.49	2.63	2.77	2.91	3.05	3.19	3.33															
SPW-6	2.64	3.05	3.40	3.73	4.03	4.31	4.57	4.81	2.57	2.97	3.32	3.64	3.93	4.20	4.45	4.70	2.89	3.23	3.53	3.82	4.08	4.33	4.56	2.42	2.79	3.12	3.42	3.69	3.95	4.19	4.42	4.65	4.88	5.11	5.34	5.57																
SPW-7	4.64	5.36	5.99	6.56	7.08	7.57	8.03	8.47	4.52	5.22	5.84	6.40	6.91	7.38	7.83	8.26	4.39	5.07	5.67	6.21	6.71	7.18	7.61	8.02	4.25	4.91	5.49	6.02	6.50	6.95	7.37	7.77	8.16	8.55	8.94	9.33																

R-407A and R-407C Capacities in Tons (at Evaporator Temperature ° F)

Valve Type	40°F													20°F													0°F													-20°F												
	Pressure Drop Across Valve (psid)													Pressure Drop Across Valve (psid)													Pressure Drop Across Valve (psid)													Pressure Drop Across Valve (psid)												
	75	100	125	150	175	200	225	250	275	300	325	350	375	400	75	100	125	150	175	200	225	250	275	300	325	350	375	400	75	100	125	150	175	200	225	250																
R-407A & R-407C SPW-0	0.08	0.09	0.10	0.11	0.12	0.13	0.14	0.14	0.08	0.09	0.10	0.11	0.11	0.12	0.13	0.14	0.07	0.08	0.09	0.10	0.11	0.12	0.12	0.13	0.07	0.08	0.09	0.10	0.11	0.12	0.13	0.14	0.15	0.16	0.17	0.18																
SPW-1	0.19	0.22	0.25	0.27	0.29	0.31	0.33	0.35	0.18	0.21	0.24	0.26	0.28	0.30	0.32	0.34	0.18	0.20	0.23	0.25	0.27	0.29	0.30	0.32	0.17	0.19	0.22	0.24	0.26	0.27	0.29	0.31	0.33	0.35	0.37	0.39																
SPW-2	0.34	0.40	0.44	0.49	0.53	0.56	0.60	0.63	0.33	0.38	0.43	0.47	0.50	0.54	0.57	0.60	0.31	0.36	0.41	0.45	0.48	0.51	0.55	0.57	0.30	0.35	0.39	0.42	0.46	0.49	0.52	0.55	0.58	0.61	0.64	0.67																
SPW-3	0.53	0.61	0.69	0.75	0.81	0.87	0.92	0.97	0.51	0.59	0.66	0.72	0.78	0.83	0.88	0.93	0.49	0.56	0.63	0.69	0.74	0.79	0.84	0.89	0.46	0.53	0.60	0.66	0.71	0.76	0.80	0.85	0.90	0.95	1.00	1.05																
SPW-4	0.92	1.06	1.19	1.30	1.40	1.50	1.59	1.68	0.88	1.02	1.14	1.25	1.35	1.44	1.53	1.61	0.84	0.97	1.09	1.19	1.28	1.37	1.46	1.54	0.80	0.93	1.03	1.13	1.22	1.31	1.39	1.46	1.54	1.62	1.70	1.78																
SPW-5	1.45	1.67	1.87	2.04	2.21	2.36	2.50	2.64	1.39	1.60	1.79	1.96	2.12	2.26	2.40	2.53	1.32	1.53	1.71	1.87	2.02	2.16	2.29	2.41	1.26	1.46	1.63	1.78	1.93	2.06	2.18	2.30	2.42	2.54	2.66	2.78																
SPW-6	2.43	2.80	3.14	3.43	3.71	3.97	4.21	4.43	2.33	2.69	3.01	3.29	3.56	3.80	4.03	4.25	2.22	2.57	2.87	3.14	3.39	3.63	3.85	4.06	2.12	2.45	2.74	3.00	3.24	3.46	3.67	3.87	4.07	4.27	4.47	4.67																
SPW-7	4.27	4.93	5.51	6.04	6.52	6.97	7.40	7.80	4.09	4.73	5.29	5.79	6.25	6.69	7.09	7.48	3.91	4.51	5.05	5.53	5.97	6.38	6.77	7.14	3.73	4.30	4.81	5.27	5.69	6.08	6.45	6.80	7.16	7.51	7.86	8.21																

Capacity tables are in tons. Assumes 100°F Liquid Temperature for R-134a, R-22, R-407A, R-407C, R-407F, R-448, R-449A, R-404A & R-507A. Assumes 40°F Liquid Temperature for R-744.

Capacity - kW

R-744 Capacities in kW (at Evaporator Temperature °C)

Valve Type	-10°C												-20°C												-30°C												-40°C											
	Pressure Drop Across Valve (bar)												Pressure Drop Across Valve (bar)												Pressure Drop Across Valve (bar)												Pressure Drop Across Valve (bar)											
	4	6	8	10	12	14	16	18	20	24	28	32	4	6	8	10	12	14	16	18	20	24	28	32	4	6	8	10	12	14	16	18	20	24	28	32	4	6	8	10	12	14	16	18	20	24	28	32
SPW-0																																																
SPW-1																																																
SPW-2																																																
SPW-3																																																
SPW-4																																																
SPW-5																																																
SPW-6																																																
SPW-7																																																

CO₂ APPROVAL PENDING

R-134a Capacities in kW (at Evaporator Temperature °C)

Valve Type	5°C												-10°C												-20°C											
	Pressure Drop Across Valve (bar)												Pressure Drop Across Valve (bar)												Pressure Drop Across Valve (bar)											
	2.5	4	5.5	7	8.5	10	11.5	13	15	18	21	25	2.5	4	5.5	7	8.5	10	11.5	13	15	18	21	25	2.5	4	5.5	7	8.5	10	11.5	13	15	18	21	25
SPW-0	0.19	0.25	0.29	0.33	0.36	0.39	0.42	0.44	0.48	0.51	0.55	0.18	0.23	0.27	0.30	0.34	0.36	0.39	0.42	0.44	0.48	0.51	0.55	0.17	0.22	0.26	0.29	0.32	0.35	0.37	0.40	0.42	0.46	0.49	0.52	
SPW-1	0.47	0.60	0.70	0.79	0.87	0.95	1.02	1.08	1.15	1.21	1.27	0.44	0.56	0.66	0.74	0.82	0.89	0.95	1.01	1.07	1.13	1.19	1.25	0.42	0.54	0.63	0.71	0.78	0.85	0.91	0.97	1.03	1.09	1.15	1.21	
SPW-2	0.85	1.08	1.26	1.43	1.57	1.70	1.83	1.94	2.04	2.13	2.21	0.80	1.01	1.18	1.34	1.47	1.60	1.71	1.82	1.92	2.01	2.10	2.18	0.76	0.96	1.13	1.27	1.40	1.52	1.63	1.74	1.84	1.93	2.02	2.11	
SPW-3	1.31	1.66	1.95	2.20	2.42	2.63	2.82	3.00	3.16	3.31	3.45	1.23	1.56	1.83	2.06	2.27	2.46	2.64	2.81	2.97	3.13	3.28	3.42	1.18	1.49	1.74	1.97	2.17	2.35	2.52	2.68	2.83	2.97	3.11	3.25	
SPW-4	2.28	2.88	3.37	3.81	4.19	4.55	4.88	5.19	5.45	5.68	5.89	2.13	2.70	3.16	3.57	3.93	4.26	4.57	4.86	5.13	5.38	5.61	5.83	2.03	2.45	2.87	3.27	3.65	4.01	4.36	4.64	4.90	5.14	5.37	5.59	
SPW-5	3.58	4.53	5.31	5.99	6.60	7.16	7.67	8.16	8.63	9.08	9.51	3.35	4.24	4.97	5.61	6.18	6.71	7.19	7.65	8.09	8.51	8.91	9.29	3.20	4.05	4.74	5.35	5.90	6.40	6.86	7.29	7.70	8.09	8.46	8.81	
SPW-6	6.01	7.61	8.92	10.1	11.1	12.0	12.9	13.7	14.4	15.0	15.6	5.64	7.13	8.36	9.43	10.4	11.3	12.1	12.9	13.6	14.3	14.9	15.5	5.38	6.80	7.97	9.00	9.91	10.8	11.5	12.3	13.0	13.7	14.4	15.0	
SPW-7	10.6	13.4	15.7	17.7	19.5	21.1	22.7	24.1	25.3	26.4	27.4	9.91	12.5	14.7	16.6	18.3	19.8	21.3	22.6	23.8	25.0	26.1	27.1	9.45	12.0	14.0	15.8	17.4	18.9	20.3	21.6	22.8	24.0	25.1	26.2	

R-22 and R-407F Capacities in kW (at Evaporator Temperature °C)

Valve Type	5°C												-10°C												-20°C												-30°C																
	Pressure Drop Across Valve (bar)												Pressure Drop Across Valve (bar)												Pressure Drop Across Valve (bar)												Pressure Drop Across Valve (bar)																
	4	6	8	10	12	14	16	18	20	24	28	32	4	6	8	10	12	14	16	18	20	24	28	32	4	6	8	10	12	14	16	18	20	24	28	32	4	6	8	10	12	14	16	18	20	24	28	32					
SPW-0	0.26	0.32	0.37	0.42	0.46	0.49	0.53	0.56	0.62	0.67	0.71	0.40	0.44	0.48	0.51	0.54	0.57	0.60	0.63	0.66	0.69	0.72	0.75	0.30	0.35	0.39	0.43	0.46	0.49	0.52	0.54	0.57	0.60	0.63	0.66	0.69	0.72	0.75	0.24	0.29	0.34	0.38	0.42	0.45	0.48	0.51	0.54	0.57	0.60	0.63			
SPW-1	0.64	0.79	0.91	1.02	1.11	1.20	1.29	1.36	1.42	1.48	1.54	0.88	0.98	1.07	1.16	1.24	1.32	1.39	1.45	1.51	1.57	1.63	1.69	0.74	0.85	0.95	1.05	1.13	1.21	1.28	1.35	1.41	1.47	1.53	1.59	1.65	1.71	1.77	1.83	1.89	1.94	2.00	2.06	2.12	2.18								
SPW-2	1.15	1.41	1.63	1.83	2.00	2.16	2.31	2.45	2.57	2.69	2.80	1.58	1.76	1.93	2.08	2.23	2.36	2.48	2.60	2.71	2.81	2.91	3.01	1.33	1.53	1.71	1.88	2.03	2.17	2.30	2.42	2.53	2.64	2.75	2.86	2.96	3.06	3.15	3.24	3.33	3.41	3.49	3.57	3.65	3.73								
SPW-3	1.78	2.18	2.52	2.82	3.09	3.34	3.57	3.78	3.97	4.14	4.30	2.42	2.71	2.98	3.22	3.44	3.65	3.85	4.03	4.20	4.36	4.51	4.66	2.05	2.37	2.64	2.90	3.13	3.35	3.55	3.73	3.90	4.06	4.21	4.35	4.49	4.62	4.75	4.87	4.99	5.11	5.22	5.33	5.44	5.54								
SPW-4	3.09	3.78	4.36	4.88	5.34	5.77	6.17	6.54	6.89	7.22	7.53	4.21	4.70	5.15	5.57	5.95	6.31	6.65	6.97	7.28	7.57	7.85	8.12	3.55	4.09	4.58	5.01	5.42	5.79	6.14	6.48	6.80	7.11	7.40	7.68	7.95	8.21	8.46	8.70	8.93	9.15	9.36	9.56	9.74	9.91								
SPW-5	4.85	5.94	6.86	7.67	8.40	9.08	9.70	10.3	10.8	11.3	11.8	6.62	7.40	8.10	8.75	9.36	9.93	10.47	10.99	11.49	11.97	12.44	12.89	5.58	6.44	7.20	7.89	8.52	9.11	9.66	10.18	10.68	11.16	11.62	12.07	12.50	12.91	13.31	13.69	14.05	14.40	14.73	15.05	15.36	15.66	15.94							
SPW-6	8.15	9.99	11.5	12.9	14.1	15.3	16.3	17.3	18.1	18.8	19.5	9.63	11.1	12.4	13.6	14.7	15.7	16.7	17.5	18.3	19.0	19.7	20.3	8.37	10.8	12.1	13.3	14.3	15.3	16.2	17.0	17.8	18.5	19.2	19.8	20.4	21.0	21.5	22.0	22.5	23.0	23.4	23.8	24.2	24.6	25.0	25.4	25.8					
SPW-7	14.3	17.6	20.3	22.7	24.8	26.8	28.7	30.4	31.8	33.1	34.3	16.9	19.6	21.9	24.0	25.9	27.7	29.3	30.8	32.2	33.5	34.8	36.0	15.5	19.0	21.3	23.3	25.2	26.9	28.5	29.9	31.2	32.4	33.6	34.7	35.8	36.8	37.8	38.7	39.6	40.4	41.2	42.0	42.8	43.5	44.2	44.9	45.6	46.2	46.9	47.5	48.1	48.7

R-407A and R-407C Capacities in kW (at Evaporator Temperature °C)

Valve Type	5°C												-10°C												-20°C												-30°C																																																																																																																																						
	Pressure Drop Across Valve (bar)												Pressure Drop Across Valve (bar)												Pressure Drop Across Valve (bar)												Pressure Drop Across Valve (bar)																																																																																																																																						
	4	6	8	10	12	14	16	18	20	24	28	32	4	6	8	10	12	14	16	18	20	24	28	32	4	6	8	10	12	14	16	18	20	24	28	32	4	6	8	10	12	14	16	18	20	24	28	32																																																																																																																											
SPW-0	0.24	0.30	0.34	0.38	0.42	0.45	0.48	0.51	0.54	0.57	0.60	0.36	0.40	0.43	0.46	0.48	0.51	0.54	0.57	0.60	0.63	0.66	0.69	0.27	0.31	0.35	0.38	0.41	0.44	0.46	0.49	0.51	0.54	0.57	0.60	0.63	0.66	0.69	0.72	0.75	0.78	0.81	0.84	0.87	0.90	0.93	0.96	0.99	1.02	1.05	1.08																																																																																																																								
SPW-1	0.59	0.72	0.84	0.93	1.02	1.11	1.18	1.25	1.31	1.37	1.42	0.88	0.97	1.04	1.12	1.18	1.24	1.30	1.35	1.40	1.45	1.50	1.55	0.75	0.85	0.95	1.05	1.12	1.19	1.25	1.31	1.37	1.42	1.47	1.52	1.57	1.62	1.67	1.72	1.77	1.82	1.87	1.92	1.97	2.02	2.07	2.12	2.17	2.22	2.27	2.32	2.37	2.42	2.47	2.52	2.57	2.62	2.67	2.72	2.77	2.82	2.87	2.92	2.97	3.02	3.07	3.12	3.17	3.22	3.27	3.32	3.37	3.42	3.47	3.52	3.57	3.62	3.67	3.72	3.77	3.82	3.87	3.92	3.97	4.02	4.07	4.12	4.17	4.22	4.27	4.32	4.37	4.42	4.47	4.52	4.57	4.62	4.67	4.72	4.77	4.82	4.87	4.92	4.97	5.02	5.07	5.12	5.17	5.22	5.27	5.32	5.37	5.42	5.47	5.52	5.57	5.62	5.67	5.72	5.77	5.82	5.87	5.92	5.97	6.02	6.07	6.12	6.17	6.22	6.27	6.32	6.37	6.42	6.47	6.52	6.57	6.62	6.67	6.72	6.77	6.82	6.87	6.92	6.97	7.02	7.07	7.12	7.17	7.22	7.27	7.32	7.37	7.42	7.47	7.52	7.57	7.62	7.67	7.72	7.77	7.82	7.87	7.92	7.97	8.02	8.07	8.12	8.17	8.22	8.27	

Capacity - kW

R-448A and R-449A Capacities in kW (at Evaporator Temperature °C)

Valve Type	-10°C																-30°C																-40°C															
	5°C				-10°C				-20°C				-30°C				-40°C				-50°C				-60°C				-70°C				-80°C															
	4	6	8	10	12	14	16	18	4	6	8	10	12	14	16	18	4	6	8	10	12	14	16	18	4	6	8	10	12	14	16	18	4	6	8	10	12	14	16	18								
SPW-0	0.24	0.30	0.35	0.39	0.42	0.46	0.49	0.52	0.23	0.28	0.33	0.37	0.40	0.43	0.46	0.49	0.22	0.27	0.32	0.35	0.39	0.42	0.45	0.47	0.21	0.26	0.30	0.34	0.37	0.40	0.43	0.46	0.20	0.25	0.29	0.32	0.36	0.38	0.41	0.43								
SPW-1	0.60	0.73	0.84	0.94	1.03	1.12	1.19	1.26	0.57	0.69	0.80	0.90	0.98	1.06	1.13	1.20	0.55	0.67	0.77	0.86	0.95	1.02	1.09	1.16	0.52	0.64	0.74	0.83	0.91	0.98	1.05	1.11	0.50	0.61	0.71	0.79	0.87	0.94	1.00	1.06								
SPW-2	1.07	1.31	1.51	1.69	1.85	2.00	2.14	2.27	1.02	1.25	1.44	1.61	1.76	1.91	2.04	2.16	0.98	1.20	1.39	1.55	1.70	1.83	1.96	2.08	0.94	1.15	1.33	1.49	1.63	1.76	1.88	2.00	0.90	1.10	1.27	1.42	1.56	1.68	1.80	1.91								
SPW-3	1.65	2.02	2.34	2.61	2.86	3.09	3.30	3.50	1.57	1.93	2.22	2.49	2.72	2.94	3.14	3.33	1.51	1.85	2.14	2.39	2.62	2.83	3.03	3.21	1.45	1.78	2.05	2.30	2.52	2.72	2.91	3.08	1.39	1.70	1.96	2.19	2.40	2.59	2.77	2.94								
SPW-4	2.86	3.50	4.04	4.52	4.95	5.35	5.72	6.07	2.72	3.33	3.85	4.30	4.71	5.09	5.44	5.77	2.62	3.21	3.70	4.14	4.53	4.90	5.24	5.55	2.51	3.08	3.56	3.98	4.36	4.70	5.03	5.33	2.40	2.94	3.39	3.79	4.16	4.49	4.80	5.09								
SPW-5	4.50	5.51	6.36	7.11	7.79	8.41	8.99	9.54	4.28	5.24	6.05	6.76	7.41	8.00	8.56	9.08	4.12	5.04	5.82	6.51	7.13	7.70	8.24	8.74	3.95	4.84	5.59	6.25	6.85	7.40	7.91	8.39	3.77	4.62	5.34	5.97	6.54	7.06	7.55	8.01								
SPW-6	7.56	9.26	10.69	11.95	13.09	14.14	15.11	16.03	7.19	8.81	10.17	11.37	12.45	13.45	14.38	15.25	6.92	8.48	9.79	10.94	11.99	12.95	13.84	14.68	6.65	8.14	9.40	10.51	11.51	12.43	13.29	14.10	6.34	7.77	8.97	10.03	10.99	11.87	12.69	13.45								
SPW-7	13.29	16.28	18.79	21.01	23.02	24.86	26.58	28.19	12.64	15.48	17.88	19.99	21.90	23.65	25.29	26.82	12.17	14.90	17.21	19.24	21.08	22.77	24.34	25.82	11.69	14.31	16.53	18.48	20.24	21.87	23.38	24.79	11.15	13.66	15.77	17.64	19.32	20.87	22.31	23.66								

R-404A and R-507A Capacities in kW (at Evaporator Temperature °C)

Valve Type	-10°C																-30°C																-40°C															
	5°C				-10°C				-20°C				-30°C				-40°C				-50°C				-60°C				-70°C				-80°C															
	4	6	8	10	12	14	16	18	4	6	8	10	12	14	16	18	4	6	8	10	12	14	16	18	4	6	8	10	12	14	16	18	4	6	8	10	12	14	16	18								
SPW-0	0.17	0.21	0.24	0.27	0.30	0.32	0.34	0.36	0.16	0.19	0.22	0.25	0.27	0.30	0.32	0.34	0.15	0.18	0.21	0.24	0.26	0.28	0.30	0.32	0.14	0.17	0.20	0.22	0.24	0.26	0.28	0.30	0.13	0.16	0.19	0.21	0.23	0.25	0.26	0.28								
SPW-1	0.42	0.51	0.59	0.66	0.72	0.78	0.83	0.88	0.39	0.47	0.55	0.61	0.67	0.72	0.77	0.82	0.37	0.45	0.52	0.58	0.63	0.68	0.73	0.78	0.34	0.42	0.49	0.54	0.59	0.64	0.69	0.73	0.32	0.39	0.45	0.51	0.56	0.60	0.64	0.68								
SPW-2	0.75	0.91	1.06	1.18	1.29	1.40	1.49	1.58	0.69	0.85	0.98	1.09	1.20	1.30	1.38	1.47	0.66	0.80	0.93	1.04	1.14	1.23	1.31	1.39	0.62	0.76	0.87	0.97	1.07	1.15	1.23	1.31	0.58	0.71	0.81	0.91	1.00	1.08	1.15	1.22								
SPW-3	1.15	1.41	1.63	1.82	2.00	2.16	2.31	2.45	1.07	1.31	1.51	1.69	1.85	2.00	2.14	2.27	1.01	1.24	1.43	1.60	1.75	1.89	2.02	2.15	0.95	1.17	1.35	1.51	1.65	1.78	1.90	2.02	0.89	1.09	1.26	1.41	1.54	1.66	1.78	1.89								
SPW-4	2.00	2.44	2.82	3.16	3.46	3.73	3.99	4.23	1.85	2.27	2.62	2.92	3.20	3.46	3.70	3.92	1.75	2.15	2.48	2.77	3.03	3.28	3.50	3.72	1.65	2.02	2.33	2.60	2.85	3.08	3.29	3.49	1.54	1.88	2.18	2.43	2.67	2.88	3.08	3.26								
SPW-5	3.14	3.84	4.44	4.96	5.44	5.87	6.28	6.66	2.91	3.56	4.11	4.60	5.04	5.44	5.82	6.17	2.76	3.37	3.90	4.36	4.77	5.16	5.51	5.85	2.59	3.17	3.66	4.10	4.49	4.85	5.18	5.50	2.42	2.96	3.42	3.83	4.19	4.53	4.84	5.13								
SPW-6	5.27	6.46	7.46	8.34	9.14	9.87	10.55	11.19	4.89	5.99	6.91	7.73	8.47	9.15	9.78	10.37	4.63	5.67	6.55	7.32	8.02	8.66	9.26	9.82	4.35	5.33	6.16	6.88	7.54	8.14	8.71	9.24	4.07	4.98	5.75	6.43	7.05	7.61	8.14	8.63								
SPW-7	9.28	11.36	13.12	14.67	16.07	17.35	18.55	19.68	8.60	10.53	12.16	13.59	14.89	16.08	17.20	18.24	8.14	9.97	11.52	12.88	14.11	15.24	16.29	17.28	7.66	9.38	10.83	12.11	13.26	14.32	15.31	16.24	7.15	8.76	10.12	11.31	12.39	13.38	14.31	15.17								

Capacity tables are in kW. Assumes 38°C Liquid Temperature for R-134a, R-22, R-407A, R-407F, R-407G, R-407H, R-408, R-449A, R-404A & R-507A. Assumes 4°C Liquid Temperature for R-744.

°C Liquid Correction Factors by Refrigerant

°C	-18	-12	-7	-1	4	10	16	21	27	32	38	43	49	54	60
R-744	1.32	1.24	1.17	1.09	1.00	0.91	0.82	0.72	0.60	--	--	--	--	--	--
R-134a	1.69	1.63	1.56	1.49	1.42	1.35	1.28	1.21	1.14	1.07	1.00	0.93	0.86	0.78	0.71
R-22	1.57	1.51	1.46	1.40	1.34	1.29	1.23	1.18	1.12	1.06	1.00	0.94	0.88	0.82	0.76
R-407A	1.78	1.70	1.63	1.55	1.48	1.40	1.32	1.24	1.16	1.08	1.00	0.92	0.83	0.75	0.66
R-407C	1.72	1.65	1.58	1.51	1.44	1.37	1.30	1.22	1.15	1.08	1.00	0.92	0.85	0.77	0.69
R-407F	1.72	1.65	1.58	1.51	1.44	1.37	1.30	1.23	1.15	1.08	1.00	0.92	0.84	0.76	0.68
R-404A	2.01	1.92	1.82	1.72	1.62	1.52	1.42	1.32	1.22	1.11	1.00	0.89	0.78	0.66	0.54
R-507A	2.05	1.95	1.85	1.75	1.64	1.54	1.44	1.33	1.22	1.11	1.00	0.89	0.77	0.65	0.52
R-448A	1.78	1.70	1.63	1.55	1.48	1.40	1.32	1.24	1.16	1.08	1.00	0.92	0.83	0.75	0.66
R-449A	1.78	1.71	1.63	1.56	1.48	1.40	1.32	1.25	1.17	1.08	1.00	0.92	0.83	0.75	0.66
R-410A	1.77	1.70	1.62	1.55	1.48	1.40	1.32	1.25	1.17	1.09	1.00	0.92	0.83	0.73	0.63

Ordering Instructions

Nomenclature

VALVE				COIL						
SPW	1	3 X 4	ODF	PWC	1	E	110-120/50-60	C	A	18
Valve Model	Port Size	Connection Size (Inlet x Outlet)	Connection Style	Coil Model	Coil Size	E - DIN or Blank	Coil Voltage 110-120 VAC/50-60 Hz 220-240 VAC/50-60 Hz 24 VAC/60 Hz	Coil Type C - Conduit or Blank	Wire Gauge A - 3/16" Insulation or Blank	Lead Length (Inches) or Blank

Product Offering

Item Description	Item Number
Valve Description	
SPW-0 3X4 ODF LESS COIL	953430
SPW-1 3X4 ODF LESS COIL	953431
SPW-2 3X4 ODF LESS COIL	953432
SPW-3 3X4 ODF LESS COIL	953433
SPW-4 3X4 ODF LESS COIL	953434
SPW-5 3X4 ODF LESS COIL	953435
SPW-6 3X4 ODF LESS COIL	953436
SPW-7 3x4 ODF LESS COIL	TBD
Coil Description	
PWC-1 24/60 CA18	335002
PWC-1 110-120/50-60 CA18	335003
PWC-1 220-240/50-60 CA18	335004
PWC-1E 24/60	335005
PWC-1E 110-120/50-60	335006
PWC-1E 220-240/50-60	335007
DIN Connector (DIN 43650 Form A)	382616
Service Parts	
KS - SPW Service Kit	953423
KS - SPW Port Service Kit	953424

NOTE: Liquid line velocity should not exceed 3 ft./second.

⚠ WARNING – USER RESPONSIBILITY

Failure or improper selection or improper use of the products described herein or related items can cause death, personal injury and property damage.

This document and other information from Parker Hannifin Corporation, its subsidiaries and authorized distributors provide product or system options for further investigation by users having technical expertise.

The user, through its own analysis and testing, is solely responsible for making the final selection of the system and components and assuring that all performance, endurance, maintenance, safety and warning requirements of the application are met. The user must analyze all aspects of the application, follow applicable industry standards, and follow the information concerning the product in the current product catalog and in any other materials provided from Parker or its subsidiaries or authorized distributors.

To the extent that Parker or its subsidiaries or authorized distributors provide component or system options based upon data or specifications provided by the user, the user is responsible for determining that such data and specifications are suitable and sufficient for all applications and reasonably foreseeable uses of the components or systems.

For safety information see the Safety Guide at www.parker.com/safety or call 1-800-CParker.

OFFER OF SALE

The items described in this document are hereby offered for sale by Parker Hannifin Corporation, its subsidiaries or its authorized distributors. This offer and its acceptance are governed by the provisions stated in the detailed "Offer of Sale" available at www.parker.com.

FOR USE ON REFRIGERATION and/or AIR CONDITIONING SYSTEMS ONLY

For more information about our products visit us at www.sporlan.com.

