

To obtain long term system life, it is important to keep contaminants to a minimum. This is particularly true of a heavy duty application such as a heat pump. Therefore, all heat pumps should have at least one filter-drier. Two standard driers are preferred, but where this creates a piping problem, then a single reversing filter-drier provides adequate protection.

USING TWO STANDARD DRIERS – OEMs may prefer using two standard driers rather than a single reversible drier. This has several advantages – more desiccant in the system, less complicated drier parts, and lower cost. Field service people should follow the recommendations of the OEM. The use of two standard driers gives protection equal to, or greater than, the use of a single reversible filter-drier, see Figure 1.

Standard driers are often installed directly ahead of the expansion device – one in the outdoor section and one in the indoor

section. Another common design is to locate both driers in the outdoor section, where they are easier to service. In this design one drier is ahead of the expansion device, and the other drier is ahead of the check valve. When installed in these locations, the flow through each drier is always in the same direction, see Figure 2. Standard filter-driers will not tolerate flow in the reverse direction. Reverse flow washes out the dirt previously collected, and also tends to result in high pressure drop.

When servicing units in the field, it is advisable to replace the original filter-drier with the next larger size, or the size recommended by the unit manufacturer. Where other information is lacking, the Sporlan C-080 Series Catch-Alls are recommended for use on heat pumps up through 2 tons; the C-160 Series Catch-Alls are recommended for 2 through 5 tons; and the C-300 Series Catch-Alls are recommended for systems of 5 to 10 tons. When replacing the original driers on a unit,

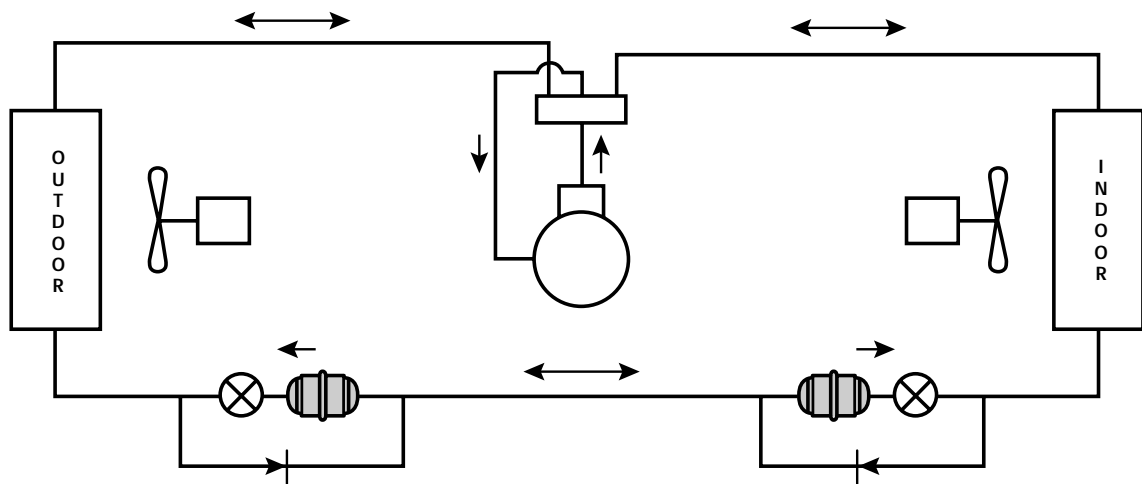

Figure 1
 Typical Two Drier System

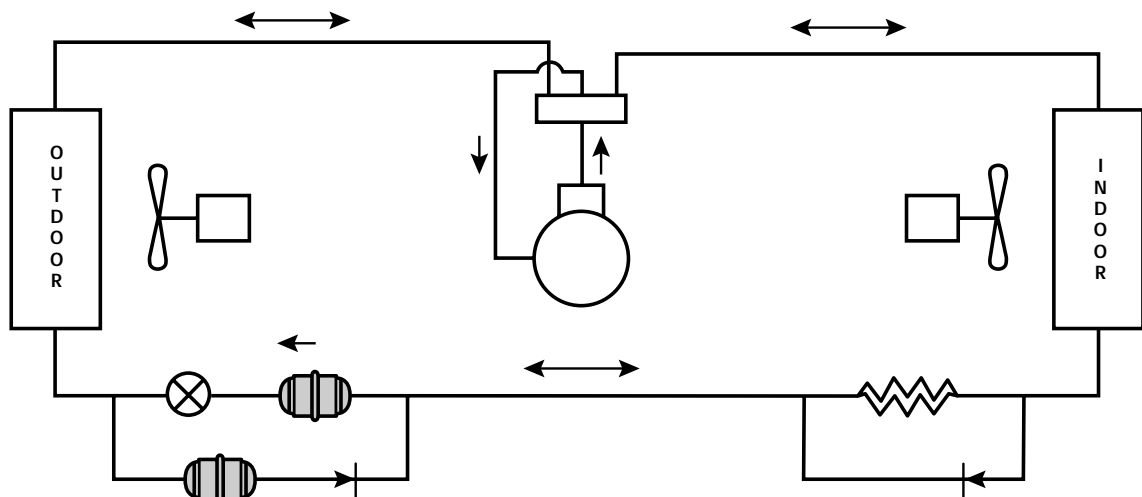

Figure 2
 Two Driers in Outdoor Section

standard filter-driers are preferred. If the original unit does not have a drier, a reversible HPC-160-HH style drier is recommended.

DRIER-CHECK VALVE COMBINATION – Some heat pumps use a drier with a check valve built into the outlet fitting of the filter-drier. Sporlan designates these driers with type numbers

such as CG-033-SV, CG-053-SV, and CG-054-SV. The “V” in the suffix indicates a check valve in the outlet fitting. Filter-driers of this type must be replaced with an identical replacement drier from the unit manufacturer. If an identical replacement is not available, then repair of the unit would require replacing the drier with a standard Catch-All Filter-Drier and a separate check valve.

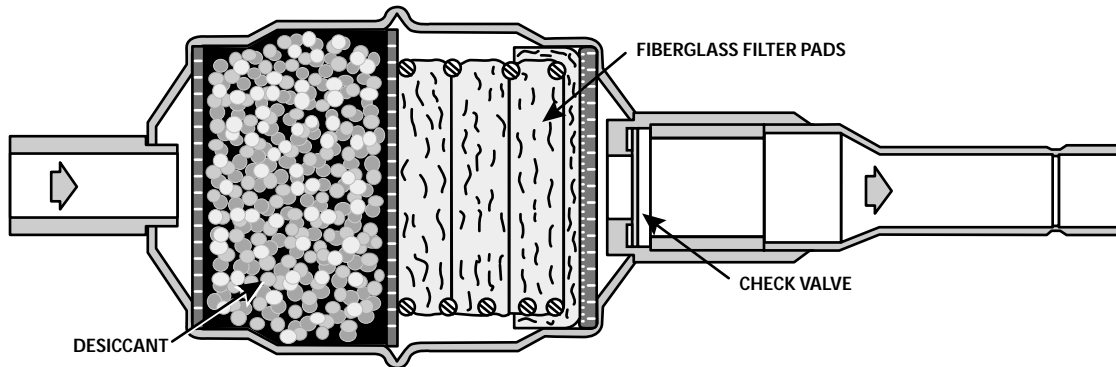

Figure 3
Filter-Drier Valve Combination

USING HPC REVERSIBLE FILTER-DRIERS – The simplest way to install a drier on a heat pump system is to use a Sporlan Reversible Filter-Drier. For most systems select an HPC-160-HH Series Catch-All with the appropriate fitting size. This reversible filter-drier series is suitable for heat pump systems up through 5 tons R-22 capacity. These driers are installed in the reversing liquid line that runs between the indoor and outdoor section. Reversible driers should never be installed in the reversing gas line that runs between the indoor coil and the 4-Way valve, or the reversing gas line that runs between the outdoor coil and the 4-Way valve. Installation in this location will not give protection to the close tolerance parts of the system, and may result in excessive pressure drop. If the reversible drier is used on a highly contaminated system, such as after a hermetic motor burnout, it is essential that the old filter-driers be removed, see Figures 4 and 5.

In the past, Sporlan offered several other types of reversible driers. These included the HCG-030 Series, HPCG-030 Series, and the HPC-080 Series. The HPC-160-HH Series are the proper replacements for any of these obsolete types.

Some heat pumps have only **one expansion device** – a bi-directional thermostatic expansion valve, or special short-tube flow restrictor. These systems are properly protected using a reversible filter-drier in the line between the expansion device and the outdoor coil. In this location the drier receives solid liquid on the cooling cycle, and a mixture of liquid and vapor on the heating cycle. Under these conditions, the Sporlan HPC-160-HH Series Catch-Alls are suitable for use up through 5 tons capacity.

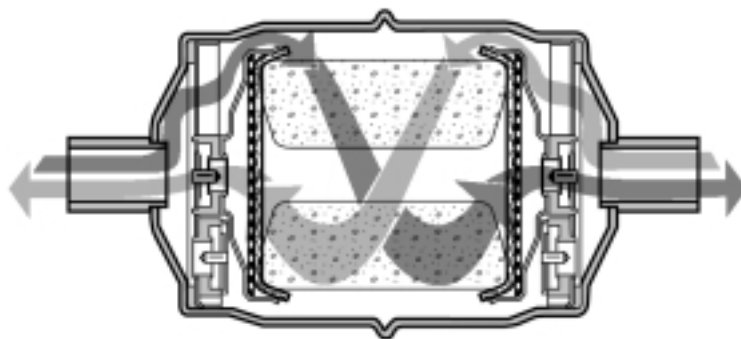

Figure 4
Reversible HPC Filter-Drier

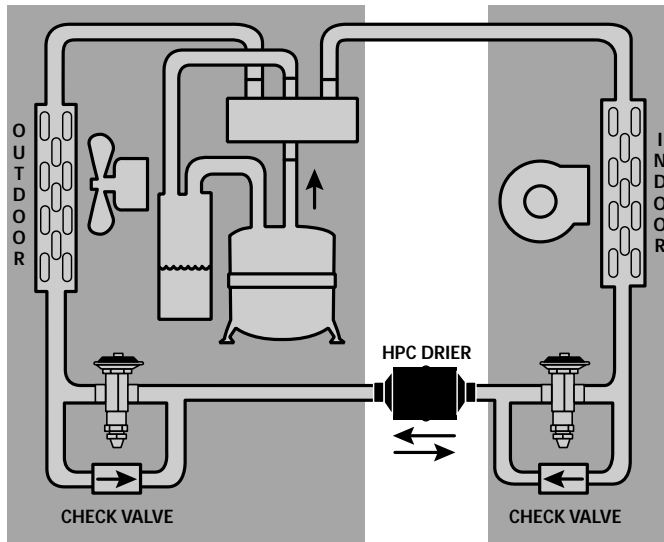

Figure 5
Reversible HPC Filter-Drier System

CLEAN-UP AFTER BURNOUT – Typical recommendations for clean-up after a hermetic motor burnout are as follows:

1. Install the same size drier (or an oversized drier) in the liquid line ahead of each expansion device, and a drier in the common suction line. In units with two liquid line driers, both should be changed.
2. Install an oversized drier in the **common** liquid line and, if possible, a drier in the common suction line. Run the unit in one mode of operation for a day. Then replace the liquid line drier with a reversible filter-drier.
3. Install a reversible filter-drier in the common liquid line. If possible, install a drier in the common suction line.

THE SUCTION LINE DRIER LOCATION – A filter-drier should be installed in the suction line to clean up a heat pump after a severe hermetic motor burnout. First, make sure the burnout is “severe” by testing the acidity of the oil from the burned out compressor using the Sporlan TA-1 Acid Test Kit. If the burnout is severe, install a standard “HH” Catch-All in the common suction line. This drier can be installed either before or after the accumulator, but always between the 4-Way valve and the compressor. If some contaminants have remained in the accumulator, then the preferred location is between the accumulator and the compressor. This is usually a crowded location on the unit, and installing the drier may be difficult. In some cases, it may be necessary to re-pipe the suction line so the drier is located outside the cabinet.

Follow the unit manufacturer’s size recommendations if possible. Where this information is not available, use

C-140-S-TT-HH Series Catch-Alls in systems up to 5 tons. Select a C-4300-S-T-HH Series Catch-All for units in the range of 5 to 10 tons. The exact model should be selected according to capacities and line size, consult Bulletin 40-10.

IF IT WON’T FIT – Most heat pumps are compact, unitary systems, with cramped piping, making it difficult to replace or install filter-driers. Here are some suggestions to solve these practical problems.

1. The reversible filter-drier is usually the simplest to install because it can be installed anywhere in the reversing liquid line leading from the outdoor section to the indoor section. Even when using the reversible filter-drier, it is important to remove any old filter-driers installed on the unit, since they may be plugged if the unit is severely contaminated. If it is not possible to replace the previous filter-driers directly, the best alternative is to remove them. Reattach the line at the drier location, and use a reversible filter-drier to protect the system in the future. The old driers must be removed; they may be severely plugged.
2. The HPC-160-HH Series Catch-Alls are recommended for most field applications requiring a reversible filter-drier. The smaller HPC-100 Series is used by OEMs and can be used on new field built systems. The HPC-100 Series is 1.0” shorter than the HPC-160-HH Series. This difference may make the HPC-100 Series more desirable on systems with cramped piping.
3. The installation of two standard driers is usually easier if both are installed in the outdoor section. One drier is installed directly ahead of the expansion valve in the outdoor coil, and the other drier is installed directly ahead of the check valve that leads to the expansion valve on the indoor coil. Each of these locations has refrigerant flow in only one direction at all times. If there is not sufficient space for two standard driers on a particular unit, perhaps satisfactory contaminant protection can be obtained by using only one drier. When there is no room inside the cabinet to install or replace the drier, the serviceman has no choice but to mount the drier outside the cabinet, and do the necessary re-piping.
4. The suction line connection on the 4-Way valve is usually the middle connection, of the three connections on one side. The single connection on the opposite side of the valve is the discharge line connection.
5. Whenever a drier is added to the liquid line of a system that did not originally have a drier, additional refrigerant charge should be added to the unit to fill the interior space of the drier. No additional charge is necessary for a drier installed in the suction line.

REVERSIBLE HEAT PUMP *Catch-All*® FILTER-DRIERS

protect your system from...



MOISTURE



DIRT



ACIDS



SLUDGE

Reversible Heat Pump Catch-Alls are designed for installation in the reversing liquid line. The smaller HPC-100 Series, using the standard Catch-All core, is designed specifically for new installations and for use on OEM equipment. The HPC-160-HH Series uses a larger core which includes activated charcoal for maximum performance in removing all types of contaminants generated from a hermetic motor burnout.

Both filter-driers consist of one core in a shell with a check

valve at either end. The check valves control the flow so the filtration occurs on the outside of the core, regardless of the flow direction.

The reliability of the check valves used in these filter-driers have passed the most rigid OEM testing – no synthetic materials are used. The check valves have been thoroughly proven in actual field performance over a period of many years. They function well, even in the presence of solid contaminants.

SPECIFICATIONS

TYPE NUMBER	CONNECTION SIZE Inches	SELECTION RECOMMENDATIONS Horsepower	DIMENSIONS - Inches		FLOW CAPACITY R-22 TONS at 2 psi ΔP	WATER CAPACITY R-22 Drops at 60 ppm		LIQUID CAPACITY Oz. R-22 100° F
			OVERALL LENGTH	DIAMETER		75° F	125° F	

FOR NEW INSTALLATIONS AND OEM USE

HPC-103	3/8 Flare	1 thru 5	6.75	3.00	4.8	100	95	12.2
HPC-103-S	3/8 Solder		5.88					
HPC-104	1/2 Flare	1 thru 5	6.94	3.00	6.3	100	95	12.2
HPC-104-S	1/2 Solder		6.00					

FOR CLEANUP AFTER BURNOUT

HPC-163-HH	3/8 Flare	1 thru 5	7.78	3.00	5.2	93	81	14.5
HPC-163-S-HH	3/8 Solder		6.92					
HPC-164-HH	1/2 Flare	1 thru 5	7.95	3.00	5.7	93	81	14.5
HPC-164-S-HH	1/2 Solder		7.07					
HPC-165-HH	5/8 Flare	1 thru 5	8.28	3.00	6.9	93	81	14.5
HPC-165-S-HH	5/8 Solder		7.35					

Core volume is 10 cubic inches for HPC-100 Series and 14 cubic inches for the HPC-160-HH Series. Core surface filtering area is 18 sq. in. for the HPC-100 Series and 26 sq. in. for the HPC-160-HH Series.

DISTRIBUTION: W

