

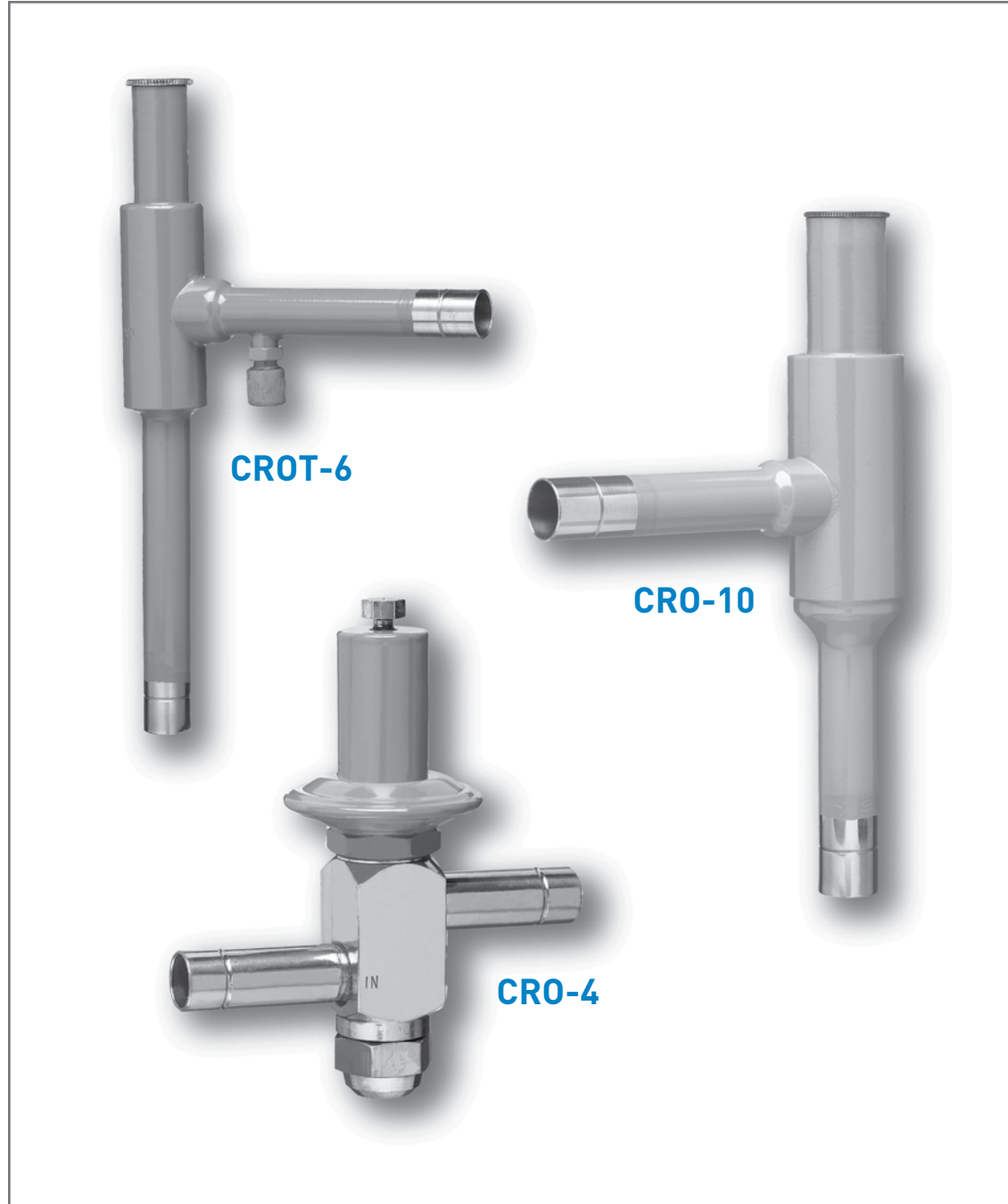

SPORLAN

Crankcase Pressure Regulating Valves

For Compressor Overload Protection



ENGINEERING YOUR SUCCESS.

Sporlan Crankcase Pressure Regulating Valves are designed to prevent overloading of the compressor motor by limiting the crankcase pressure during and after a defrost cycle or after a normal shutdown period. When properly installed in the suction line, these valves automatically throttle the vapor flow from the evaporator until the compressor can handle the load. Sporlan manufactures three adjustable models: the CRO-4, CRO(T)-6 and CRO(T)-10. All models are available in various adjustment ranges.

OPERATION

VALVE GRADIENT – or any pressure sensitive valve to modulate to a more closed or open position, a change in the operating pressure is required. The unit change in the valve stroke for a given change in the operating pressure is called the valve gradient. Every valve has a specific gradient designed for the best possible operation. Valve sensitivity or how the CRO valve reacts to a change in suction (crankcase) pressure and the valve’s capacity rating are functions of the valve gradient. For a given set of operating conditions, a greater difference between the suction pressure and the valve setting strokes the valve more in the open direction to obtain greater valve capacity. Once the valve is fully opened, only an increase in pressure drop across the port will increase valve capacity. Because of these interacting factors, all must be considered when a crankcase pressure regulating valve is being selected.

CRO VALVE OPERATION – Crankcase pressure regulating valves (sometimes called suction pressure regulating valves) are sensitive only to their outlet pressure (compressor crankcase or suction pressure). To indicate this trait, the designation for our crankcase pressure regulating valves describes the operation: **Close on Rise of Outlet** pressure or CRO. Figure 1 illustrates either a CRO(T)-6 or CRO(T)-10. In these valve models, the inlet pressure is exerted on the underside of the bellows and on top of the seat disc. Since the effective area of the bellows is equal to the area of the port, the **inlet** pressure cancels out and does not affect valve operation. The valve **outlet** pressure acting on the bottom of the disc exerts a force in the closing direction. This force is opposed by the adjustable spring force and these are the operating forces of the CRO. The CRO’s pressure setting is determined by the spring force. The CRO-4 is shown in Figure 2. This model has balanced piston design which cancels out both inlet and outlet pressure from acting on the piston. The outlet pressure is sensed under the diaphragm around the pushrod. This pressure, combined with the spring force under the piston, is exerted in the closing direction. The opening force is provided by the adjustable spring element assembly. The CRO’s pressure setting is determined by the spring force exerted on top of the diaphragm. Thus, by increasing the adjusting spring force, the valve setting or the pressure at which the valve will close is increased.

As long as the valve outlet pressure is greater than the valve pressure setting, the valve will remain closed. As the outlet pressure is reduced, the valve will open and pass refrigerant vapor into the compressor. Further reduction of the outlet pressure will allow the valve to open to its rated position where the rated pressure drop will exist across the valve port. An increase in the outlet pressure will cause the valve to throttle until the pressure setting is reached.

The CRO(T)-6 and CRO(T)-10 valves are built with an anti-chatter device which is designed to minimize the damaging effect of compressor pulsations on the valve’s bellows. This feature allows the CRO to function at low load conditions without any chattering or other operational difficulties. The CRO-4 does not require this device because the pulsations are damped before reaching the underside of the diaphragm.

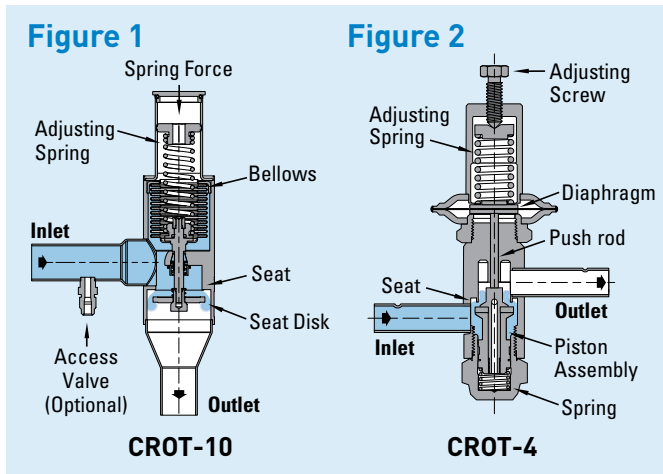

⚠ WARNING – USER RESPONSIBILITY

Failure or improper selection or improper use of the products described herein or related items can cause death, personal injury and property damage.

This document and other information from Parker Hannifin Corporation, its subsidiaries and authorized distributors provide product or system options for further investigation by users having technical expertise.

The user, through its own analysis and testing, is solely responsible for making the final selection of the system and components and assuring that all performance, endurance, maintenance, safety and warning requirements of the application are met. The user must analyze all aspects of the application, follow applicable industry standards, and follow the information concerning the product in the current product catalog and in any other materials provided from Parker or its subsidiaries or authorized distributors.

To the extent that Parker or its subsidiaries or authorized distributors provide component or system options based upon data or specifications provided by the user, the user is responsible for determining that such data and specifications are suitable and sufficient for all applications and reasonably foreseeable uses of the components or systems.

For safety information see the Safety Guide at www.parker.com/safety or call 1-800-CParker.

OFFER OF SALE

The items described in this document are hereby offered for sale by Parker Hannifin Corporation, its subsidiaries or its authorized distributors. This offer and its acceptance are governed by the provisions stated in the detailed “Offer of Sale” elsewhere in this document or available at www.parker.com.

FOR USE ON REFRIGERATION and/or AIR CONDITIONING SYSTEMS ONLY

For more information about our products visit us at www.sporlan.com.

Bulletin 90-10, July 2012 supersedes Bulletin 90-10, July 2003 and all prior publications.

APPLICATION

The function of the crankcase pressure regulating valve is similar to the practice of manually throttling the compressor suction service valve until the machine can handle the load. While either device will increase the pulldown period, they are essential in order to protect the compressor. To properly apply a crankcase pressure regulating valve, several system and valve factors must be considered.

TYPE OF SYSTEM – A crankcase pressure regulating valve is applicable on any system on which the compressor motor can be overloaded due to high suction pressures. This condition is determined by the specific system design pressures and the compressor manufacturer's application limitations. Care should be taken to completely evaluate a possible compressor overload condition on any refrigeration system being designed.

CRO LOCATION – As Figure 3 illustrates, the CRO valve is applied in the suction line between the evaporator and the compressor. Normally, the CRO is installed downstream of any other controls or accessories. However, on some applications it may be advisable or necessary for special purposes to locate other system components, e.g., an accumulator, downstream of the CRO. This is satisfactory as long as the CRO valve is applied as a crankcase pressure regulating valve only.

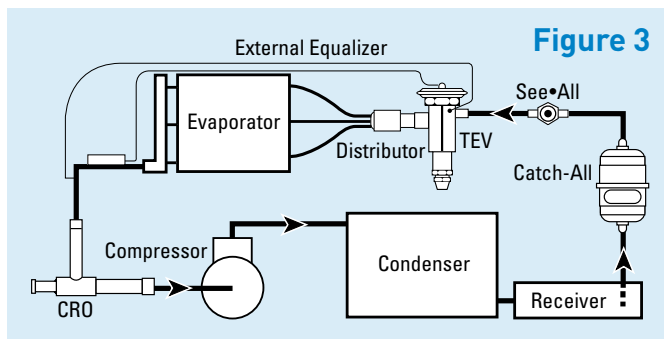

CRO valves are designed for application in the suction line only and **should not** be applied in hot gas bypass lines or any other refrigerant line of a refrigeration system. Sporlan manufactures other types of pressure regulating valves for other applications . . . Evaporator Pressure Regulating Valves-ORIT models, see Bulletin 90-20 . . . Head Pressure Control Valves-ORI, OROA, and ORD models, see Bulletin 90-30 . . . Discharge Bypass Valves for compressor capacity control, see Bulletin 90-40 and Defrost Differential Valves, see Bulletin 90-50.

PIPING INSTRUCTIONS – Figure 3 is a piping schematic only to illustrate the general location of the CRO valve in the system. Sporlan recommends that recognized piping references be consulted for assistance in piping procedures. Sporlan is not responsible for system design, any damage arising from faulty system design, or for misapplication of its products. If these valves are applied in any manner other than as described in this bulletin, the Sporlan warranty is void.

Inlet strainers are supplied for all CRO models except those with flare connections. Depending on system cleanliness, a suction filter or strainer may be required to protect models with SAE Flare connections.

ACCESS VALVE/PRESSURE TAP CONNECTION - CRO(T)-6 and CRO(T)-10 – On many systems it is desirable to have a pressure tap on the inlet side of the crankcase pressure regulating valve. Therefore, an access valve is located on the inlet connection and is indicated by adding a “T” to the valve’s designation-CROT. If a pressure tap for a gauge that can be used periodically is desired, the 1/4” SAE access valve connection is used. If a pressure actuated defrost control is used on a refrigeration system, it can be connected to the inlet or evaporator side of the CROT by utilizing the access valve connection without the valve core and cap. The connection can be used for purposes other than those mentioned here, either with or without the access valve core.

CRO'S AND OTHER CONTROL VALVES – The pressure limit type thermostatic expansion valve is designed to limit the suction pressure during normal system operation. However, during and after a hot gas defrost cycle or after a shutdown period, the pressure in the evaporator may be such that the compressor motor cannot handle the load imposed on it. In such cases, the pressure limit type TEV is of no help and a CRO **must** be used. While the pressure limit type expansion valve **can** be used with the CRO, pulldown time may be adversely affected if the expansion valve MOP and the CRO setting are too close to one another. Therefore, unless an extended pulldown time is tolerable or the MOP and the CRO setting are sufficiently far enough apart, Sporlan does not recommend that the two devices be used on the same system.

If the CRO valve is required on a system with a Sporlan Discharge Bypass Valve, some care must be taken with each valve’s setting. Since the bypass valve’s function is to keep the compressor suction pressure above a certain level during low load operation, the pressure setting of the CRO must be **higher** than the bypass valve setting or the CRO will be constantly throttling the flow to protect the compressor.

PRESSURE SETTINGS – The CRO(T)-6 and CRO(T)-10 valves have adjustment ranges of 0/60 psig or 30/110 psig. The CRO-4 has adjustment ranges of 0/20, 0/50 or 0/75 psig. For applications requiring settings beyond these ranges, contact your Sporlan representative.

STANDARD FACTORY SETTINGS			
Valve Type	Adjustment Range - psig	Saturated Setting	Average psi change per turn
CRO-4	0/20	15	3-1/3
CRO-4	0/50	30	6
CRO-4	0/75	50	10
CRO(T)-6	0/60	30	6
CRO(T)-10			2.5
CRO(T)-6	30/110	70	12
CRO(T)-10			5

The standard factory pressure settings of these valves are listed above. The proper pressure setting for a CRO on a given system is one that is low enough to protect the compressor from an overloaded condition; and, high enough so the compressor capacity and evaporator pulldown time are not penalized. Also, as indicated in the discussion on capacity ratings, the setting should be kept as high as possible to get the maximum possible capacity from the CRO. Therefore, on most

systems the best setting is the one that allows maximum system capacity while adequately protecting the compressor against overload. When other pressure settings are required, they are available on **special** order.

CRO's should be adjusted at startup when the pressure in the evaporator is above the desired setting. The final valve setting should be below the maximum suction pressure recommended by the compressor or unit manufacturer. Complete adjustment instructions are given in Bulletin 90-11.

As previously indicated, the pressure setting of the CRO must be **higher** than the discharge bypass valve setting whenever these two valves are used on the same system.

SELECTION FACTORS – Three factors must be considered when applying CRO valves – the design suction pressure after pulldown, the maximum allowable suction pressure recommended by the compressor manufacturer, and the pressure drop across the valve at **design** load. The difference between the design suction pressure and the maximum allowable suction pressure determines how much of the valve stroke can be used. Therefore, the maximum capacity the CRO can handle is a function of these factors.

The third factor – pressure drop across the valve – is important because suction line pressure losses penalize system capacity. The pressure drop across the CRO should be kept to a minimum; and, the lower the evaporator temperature, the lower the allowable pressure drop. Normally, a low temperature system can only tolerate a pressure drop of 1/2 to 1 psi across the CRO valve. The maximum pressure drop for any refrigeration system is 2 psi. For that reason the capacity rating table only shows pressure drop values of 1/2, 1, and 2 psi. The Selection Procedures Section shows a typical selection for a low temperature system.

PARALLELING CRO'S – For systems with more capacity than the largest CRO can handle, two or more CRO's can be installed in parallel. They should be piped so the pressure drop across each valve is the same. If it is necessary to adjust valves in parallel, they should be adjusted equal amounts so they operate together. If one valve is out-of-adjustment with the others, it is suggested that all valves be backed clear out and then readjusted uniformly.

SELECTION PROCEDURES

The actual selection of a CRO involves five basic system conditions: 1. Refrigerant 2. System capacity in tons 3. Design suction pressure or saturation temperature after pulldown 4. Maximum allowable suction pressure or saturation temperature recommended by the compressor or unit manufacturer (this is the valve setting) 5. Allowable pressure drop across the valve at **design** load.

The pressure difference between items 3 and 4 determines how much of the valve stroke is utilized. Therefore, the valve setting should be kept as high as possible without exceeding the recommendation of the compressor or unit manufacturer. When the full stroke of the valve is used, the only thing that will increase valve capacity is to take more pressure drop across the valve. Since excessive suction line pressure losses penalize system capacity, the pressure drop across the CRO should be kept to a minimum – the lower the evaporator temperature, the less pressure drop allowed.

EXAMPLE: Select a crankcase pressure regulating valve for a **Refrigerant 404A system** with a capacity of 1.2 tons and a design evaporator temperature of -20°F (16.3 psig saturation suction pressure). The maximum allowable suction pressure (valve setting) is **30 psig**. Referring to the Refrigerant 404A capacity table for these operating conditions, we find that the CRO-10-0/60 has a capacity of 1.13 tons for a pressure drop of approximately 1/2 psi. Therefore, the CRO-10-0/60 with the desired connections is the correct selection for this system.

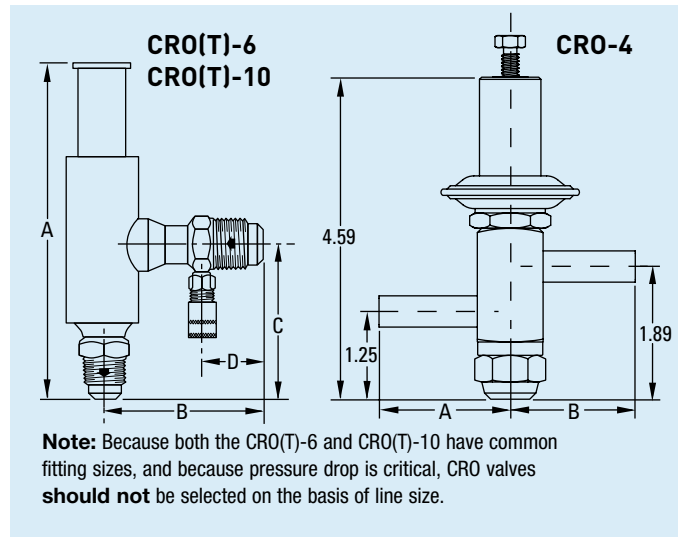

MATERIALS AND CONSTRUCTION DETAILS

Valve Type	Port Size Inches	Element Type and Material	Connections		Body Material	Seating Material	Type of Joints
			Type	Material			
CRO-4	1/2	Diaphragm -Stainless Steel	ODF Solder	Copper	Brass	Teflon to Metal	Knife Edge, Metal to Metal
			SAE Flare	Brass			
CRO(T)-6	3/4	Bellows -Brass	ODF Solder	Copper	Brass	Metal to Metal	Hermetic Construction
			SAE Flare	Brass			
CRO(T)-10	1.218	Bellows -Brass	ODF Solder	Copper	Brass	Metal to Metal	Hermetic Construction

SPECIFICATIONS

Valve Type	Nominal Adjustment Range - psig	Connections - Inches Standard Connections in BOLD	Dimensions - Inches					Weight - Pounds		Inlet Strainer Part Number
			A	B	C	D	Socket Depth	Net	Shipping	
CRO-4	0/20, 0/50 or 0/75	3/8 ODF Solder	1.87	1.78	—	—	0.32	1.00	1.15	825-003
		1/2 ODF Solder	2.12	2.03	—	—	0.37			825-004
		3/8 SAE Flare	1.65	1.56	—	—	—			Not Available
		1/2 SAE Flare	1.84	1.75	—	—	—			Not Available
CRO(T)-6	0/60 or 30/110	5/8 ODF Solder	9.82	5.29	6.37	3.65	0.5	1.00	1.25	825-5
		7/8 ODF Solder	9.82	5.29	6.37	3.75	0.75	1.00	1.25	825-7
		1-1/8 ODF Solder	9.82	5.29	6.37	3.75	0.91	1.25	1.50	825-9
		1/2 SAE Flare	6.19	2.62	2.81	0.94	—	1.00	1.25	Not Available
		5/8 SAE Flare	6.37	2.81	3.00	1.06	—	1.00	1.25	Not Available
CRO(T)-10	0/60 or 30/110	7/8 ODF Solder	11.01	5.69	6.50	3.25	0.75	2.50	2.75	825-7
		1-1/8 ODF Solder	11.01	5.69	6.50	3.25	0.91	2.50	2.75	825-9
		1-3/8 ODF Solder	11.01	5.69	6.50	3.25	0.97	2.50	2.75	825-11

The CRO-4 is a Recognized Component by Underwriter's Laboratories Inc. for the U.S. and Canada – Guide SFJQ2/SFJQ8, File No. SA5460. Maximum rated pressure of 500 psig (3447 kPa).
 The CRO(T)-6 and CRO(T)-10 are Recognized Components by Underwriter's Laboratories Inc. for the U.S. and Canada – Guide SFJQ2/SFJQ8, File No. SA5460. Canadian Standards Association, File LR36628. Maximum rated pressure of 450 psig (3102 kPa).

REFRIGERANT 22 - CAPACITIES – TONS

Capacities based on 100°F condensing temperature, 10°F superheat and 0°F subcooling

Type and Adjustment Range	Design Evaporator Temperature °F	Saturated Suction Pressure – psig (Reference)	Pressure Drop Across Valve (psi)																	
			0.5						1						2					
			Valve Settings (psig)																	
			10	20	30	40	50	60	10	20	30	40	50	60	10	20	30	40	50	60
CRO-4 0/20	-40	0.6	0.09	0.09	—	—	—	—	0.13	0.13	—	—	—	—	0.17	0.20	—	—	—	—
	-30	4.9	0.09	0.11	—	—	—	—	0.13	0.15	—	—	—	—	0.17	0.20	—	—	—	—
	-20	10.2	—	0.12	—	—	—	—	—	0.17	—	—	—	—	—	0.23	—	—	—	—
	-10	16.5	—	0.11	—	—	—	—	—	0.15	—	—	—	—	—	0.21	—	—	—	—
CRO-4 0/50	-40	0.6	0.08	0.09	0.09	0.09	—	—	0.13	0.13	0.13	0.13	0.13	—	0.14	0.19	0.24	0.17	0.17	—
	-30	4.9	0.08	0.10	0.11	0.11	—	—	0.11	0.14	0.15	0.15	0.15	—	0.14	0.19	0.20	0.20	0.20	—
	-20	10.2	—	0.10	0.12	0.12	0.12	—	—	0.14	0.17	0.17	0.17	—	—	0.19	0.23	0.23	0.23	—
	-10	16.5	—	0.10	0.12	0.14	0.14	—	—	0.13	0.17	0.19	0.19	—	—	0.18	0.24	0.27	0.27	—
	0	24.0	—	—	0.12	0.15	0.16	—	—	—	0.16	0.21	0.22	—	—	—	0.22	0.29	0.30	—
	10	32.8	—	—	—	0.14	0.17	—	—	—	—	0.19	0.24	—	—	—	—	0.26	0.33	—
CRO-4 0/75	-40	0.6	0.07	0.09	0.09	0.09	0.09	0.09	0.13	0.12	0.13	0.13	0.13	0.13	0.13	0.17	0.22	0.17	0.17	0.17
	-30	4.9	0.08	0.09	0.11	0.11	0.11	0.11	0.10	0.13	0.15	0.15	0.15	0.15	0.14	0.17	0.20	0.20	0.20	0.20
	-20	10.2	—	0.10	0.11	0.12	0.12	0.12	—	0.13	0.16	0.17	0.17	0.17	—	0.18	0.22	0.23	0.23	0.23
	-10	16.5	—	0.09	0.12	0.14	0.14	0.14	—	0.13	0.16	0.19	0.19	0.19	—	0.18	0.22	0.27	0.27	0.27
	0	24.0	—	—	0.11	0.14	0.16	0.16	—	—	0.16	0.19	0.22	0.22	—	—	0.22	0.29	0.30	0.30
	10	32.8	—	—	—	0.13	0.16	0.18	—	—	—	0.18	0.22	0.25	—	—	—	0.25	0.31	0.34
	20	43.1	—	—	—	—	0.14	0.17	—	—	—	—	0.20	0.25	—	—	—	—	0.28	0.34
30	55.0	—	—	—	—	—	0.15	—	—	—	—	—	—	—	—	—	—	—	—	

Type and Adjustment Range	Design Evaporator Temperature °F	Saturated Suction Pressure – psig (Reference)	Pressure Drop Across Valve (psi)																	
			0.5						1						2					
			Valve Settings (psig)																	
			10	20	30	40	50	60	10	20	30	40	50	60	10	20	30	40	50	60
CRO(T)-6 0/60	-40	0.6	0.26	0.39	0.52	0.64	0.64	0.64	0.36	0.54	0.72	0.89	0.89	0.89	0.46	0.71	0.97	1.21	1.21	1.21
	-20	10.2	—	0.36	0.52	0.69	0.84	0.84	—	0.49	0.72	0.96	1.18	1.18	—	0.66	0.97	1.32	1.62	1.62
	-10	16.5	—	0.29	0.47	0.66	0.84	0.95	—	0.39	0.66	0.92	1.18	1.34	—	0.52	0.90	1.27	1.65	1.85
	0	24.0	—	—	0.38	0.59	0.80	1.01	—	—	0.52	0.82	1.12	1.42	—	—	0.71	1.13	1.55	1.97
	10	32.8	—	—	—	0.45	0.69	0.92	—	—	—	0.63	0.96	1.30	—	—	—	0.86	1.33	1.81
	20	43.1	—	—	—	—	0.50	0.76	—	—	—	—	0.70	1.07	—	—	—	—	0.96	1.48
	30	55.0	—	—	—	—	—	0.50	—	—	—	—	—	0.70	—	—	—	—	—	0.96
CRO(T)-10 0/60	-40	0.6	0.75	1.40	1.40	1.40	1.40	1.40	1.06	1.98	1.98	1.98	1.98	1.98	1.48	2.78	2.78	2.78	2.78	2.78
	-20	10.2	—	1.02	1.83	1.83	1.83	1.83	—	1.43	2.58	2.58	2.58	2.58	—	2.01	3.63	3.63	3.63	3.63
	-10	16.5	—	0.41	1.58	2.07	2.07	2.07	—	0.58	2.23	2.92	2.92	2.92	—	0.80	3.15	4.11	4.11	4.11
	0	24.0	—	—	0.79	2.11	2.32	2.32	—	—	1.11	2.98	3.28	3.28	—	—	1.57	4.20	4.63	4.63
	10	32.8	—	—	—	1.06	2.54	2.60	—	—	—	1.50	3.58	3.67	—	—	—	2.11	5.06	5.18
	20	43.1	—	—	—	—	1.14	2.78	—	—	—	—	1.61	3.93	—	—	—	—	2.27	5.55
30	55.0	—	—	—	—	—	0.93	—	—	—	—	—	1.31	—	—	—	—	—	1.84	

REFRIGERANT 22 - CAPACITIES – TONS (cont.)

Capacities based on 100°F condensing temperature, 10°F superheat and 0°F subcooling

Type and Adjustment Range	Design Evaporator Temperature °F	Saturated Suction Pressure – psig (Reference)	Pressure Drop Across Valve (psi)																	
			0.5						1						2					
			Valve Settings (psig)																	
			40	50	60	70	80	90	40	50	60	70	80	90	40	50	60	70	80	90
CRO(T)-6 30/110	0	24.0	0.48	0.62	0.76	0.90	1.05	1.07	0.66	0.87	1.07	1.27	1.47	1.51	0.91	1.19	1.48	1.76	2.04	2.10
	10	32.8	0.26	0.55	0.71	0.87	1.03	1.19	0.55	0.78	1.00	1.22	1.45	1.67	0.75	1.07	1.39	1.07	2.02	2.34
	20	43.1	–	0.44	0.61	0.79	0.97	1.14	–	0.61	0.86	1.11	1.36	1.61	–	0.84	1.19	1.54	1.90	2.25
	30	54.9	–	–	0.45	0.64	0.84	1.04	–	–	0.63	0.91	1.18	1.46	–	–	0.87	1.26	1.65	2.04
	40	68.6	–	–	–	0.42	0.64	0.85	–	–	0.59	0.90	1.20	–	–	–	–	0.81	1.24	1.67
CRO(T)-10 30/110	0	24.0	1.43	2.32	2.32	2.32	2.32	2.32	2.02	3.28	3.28	3.28	3.28	3.28	2.84	4.62	4.62	4.62	4.62	4.62
	10	32.8	0.72	1.72	2.60	2.60	2.60	2.60	1.02	2.43	3.67	3.67	3.67	3.67	1.43	3.42	5.18	5.18	5.18	5.18
	20	43.1	–	0.78	1.89	2.89	2.89	2.89	–	1.10	2.66	4.09	4.09	4.09	–	1.54	3.76	5.77	5.77	5.77
	30	54.9	–	–	0.64	1.86	3.09	3.21	–	–	0.90	2.63	4.37	4.53	–	–	1.25	3.71	6.17	6.40
	40	68.6	–	–	–	–	1.57	2.92	–	–	–	–	2.22	4.13	–	–	–	–	3.12	5.84

REFRIGERANT 134a - CAPACITIES – TONS

Capacities based on 100°F condensing temperature, 10°F superheat and 0°F subcooling

Type and Adjustment Range	Design Evaporator Temperature °F	Saturated Suction Pressure – psig (Reference)	Pressure Drop Across Valve (psi)																	
			0.5						1						2					
			Valve Settings (psig)																	
			10	20	30	40	50	60	10	20	30	40	50	60	10	20	30	40	50	60
CRO-4 0/20	-40	14.7	0.06	0.06	–	–	–	–	0.08	0.08	–	–	–	–	0.10	0.10	–	–	–	–
	-30	9.7	0.07	0.07	–	–	–	–	0.09	0.09	–	–	–	–	0.12	0.12	–	–	–	–
	-20	3.6	0.08	0.08	–	–	–	–	0.11	0.11	–	–	–	–	0.15	0.15	–	–	–	–
	-10	2.0	0.09	0.10	–	–	–	–	0.13	0.13	–	–	–	–	0.17	0.18	–	–	–	–
CRO-4 0/50	-40	14.7	0.06	0.06	0.06	0.06	–	–	0.07	0.08	0.08	0.08	0.08	–	0.09	0.10	0.10	0.10	0.10	–
	-30	9.7	0.06	0.07	0.07	0.07	–	–	0.09	0.09	0.09	0.09	–	0.11	0.12	0.12	0.12	0.12	–	
	-20	3.6	0.07	0.08	0.08	0.08	0.08	–	0.10	0.11	0.11	0.11	–	0.12	0.15	0.15	0.15	0.15	–	
	-10	2.0	0.07	0.09	0.10	0.10	0.10	–	0.10	0.13	0.13	0.13	0.13	–	0.13	0.17	0.18	0.18	0.18	–
	0	6.5	0.08	0.10	0.11	0.11	0.11	–	0.10	0.14	0.15	0.15	0.15	–	0.14	0.18	0.21	0.21	0.21	–
	10	12.0	–	0.10	0.12	0.13	0.13	–	–	0.14	0.17	0.18	0.18	–	–	0.19	0.24	0.24	0.24	–
CRO-4 0/75	20	18.4	–	–	0.12	0.14	0.14	–	–	0.17	0.20	0.20	–	–	–	0.24	0.28	0.28	–	
	30	26.1	–	–	–	0.15	0.16	–	–	0.16	0.21	0.23	–	–	–	0.22	0.28	0.32	–	
	-40	14.7	0.05	0.06	0.06	0.06	0.06	0.07	0.08	0.08	0.08	0.08	0.08	0.08	0.08	0.10	0.10	0.10	0.10	0.10
	-30	9.7	0.06	0.07	0.07	0.07	0.07	0.07	0.08	0.09	0.09	0.09	0.09	0.09	0.10	0.12	0.12	0.12	0.12	0.12
	-20	3.6	0.07	0.08	0.08	0.08	0.08	0.08	0.09	0.11	0.11	0.11	0.11	0.11	0.12	0.14	0.15	0.15	0.15	0.15
	-10	2.0	0.07	0.09	0.10	0.10	0.10	0.10	0.10	0.12	0.13	0.13	0.13	0.13	0.13	0.16	0.18	0.18	0.18	0.18
	0	6.5	0.07	0.09	0.11	0.11	0.11	0.11	0.10	0.13	0.15	0.15	0.15	0.15	0.14	0.17	0.21	0.21	0.21	0.21
	10	12.0	–	0.09	0.11	0.13	0.13	0.13	–	0.13	0.16	0.18	0.18	0.18	–	0.18	0.24	0.24	0.24	0.24
CRO(T)-6 0/60	20	18.4	–	–	0.12	0.14	0.14	–	–	0.16	0.19	0.20	0.20	–	–	0.22	0.27	0.28	0.28	
	30	26.1	–	–	–	0.14	0.16	0.16	–	–	0.16	0.19	0.23	0.23	–	–	0.21	0.27	0.32	0.32
	40	35.0	–	–	–	0.13	0.16	0.18	–	–	–	0.18	0.22	0.26	–	–	–	–	0.31	0.36

Type and Adjustment Range	Design Evaporator Temperature °F	Saturated Suction Pressure – psig (Reference)	Pressure Drop Across Valve (psi)																	
			0.5						1						2					
			Valve Settings (psig)																	
			10	20	30	40	50	60	10	20	30	40	50	60	10	20	30	40	50	60
CRO(T)-6 0/60	-40	14.7	0.23	0.31	0.39	0.40	0.40	0.40	0.29	0.41	0.53	0.55	0.55	0.55	0.35	0.51	0.68	0.71	0.71	0.71
	-20	3.6	0.25	0.37	0.48	0.56	0.56	0.56	0.34	0.50	0.66	0.78	0.78	0.78	0.43	0.66	0.88	1.05	1.05	1.05
	-10	2.0	0.25	0.38	0.51	0.64	0.65	0.65	0.34	0.52	0.71	0.89	0.91	0.91	0.43	0.69	0.95	1.21	1.24	1.24
	0	6.5	0.22	0.37	0.52	0.67	0.76	0.76	0.30	0.51	0.73	0.94	1.05	1.05	0.38	0.68	0.98	1.28	1.45	1.45
	10	12.0	–	0.34	0.51	0.69	0.85	0.87	–	0.46	0.71	0.95	1.19	1.21	–	0.62	0.95	1.30	1.64	1.67
	20	18.4	–	0.26	0.45	0.65	0.84	0.99	–	0.35	0.63	0.90	1.18	1.38	–	0.47	0.85	1.24	1.63	1.92
CRO(T)-10 0/60	30	26.1	–	–	0.35	0.56	0.78	1.01	–	–	0.48	0.79	1.10	1.41	–	–	0.64	1.08	1.52	1.96
	40	35.0	–	–	–	0.42	0.67	0.71	–	–	–	0.58	0.93	0.99	–	–	–	0.79	1.28	1.38
	-40	14.7	0.88	0.90	0.90	0.90	0.90	0.90	1.23	1.26	1.26	1.26	1.26	1.26	1.72	1.76	1.76	1.76	1.76	1.76
	-20	3.6	0.82	1.23	1.23	1.23	1.23	1.23	1.16	1.74	1.74	1.74	1.74	1.74	1.61	2.44	2.44	2.44	2.44	2.44
	-10	2.0	0.65	1.43	1.43	1.43	1.43	1.43	0.92	2.02	2.02	2.02	2.02	2.02	1.28	2.83	2.83	2.83	2.83	2.83
	0	6.5	0.33	1.26	1.64	1.64	1.64	1.64	0.46	1.78	2.32	2.32	2.32	2.32	0.63	2.50	3.26	3.26	3.26	3.26
CRO(T)-10 0/60	10	12.0	–	0.86	1.88	1.88	1.88	1.88	–	1.21	2.65	2.65	2.65	2.65	–	1.70	3.74	3.74	3.74	3.74
	20	18.4	–	0.20	1.41	2.13	2.13	2.13	–	0.27	1.98	3.02	3.02	3.02	–	0.37	2.79	4.25	4.25	4.25
	30	26.1	–	–	0.54	1.91	2.41	2.41	–	–	0.76	2.70	3.42	3.42	–	–	1.07	3.81	4.81	4.81
	40	35.0	–	–	–	0.77	2.31	2.61	–	–	–	1.09	3.27	3.69	–	–	–	1.53	4.61	5.21

Numbers shown in italic indicate vacuum in inches.

REFRIGERANT 134a - CAPACITIES – TONS (cont.)

Capacities based on 100°F condensing temperature, 10°F superheat and 0°F subcooling

Type and Adjustment Range	Design Evaporator Temperature °F	Saturated Suction Pressure – psig (Reference)	Pressure Drop Across Valve (psi)																	
			0.5						1						2					
			Valve Settings (psig)																	
			40	50	60	70	80	90	40	50	60	70	80	90	40	50	60	70	80	90
CRO(T)-6 30/110	0	6.5	0.51	0.61	0.71	0.76	0.76	0.76	0.70	0.85	0.99	1.05	1.05	1.05	0.95	1.15	1.36	1.45	1.45	1.45
	10	12.0	0.52	0.64	0.75	0.87	0.87	0.87	0.72	0.89	1.05	1.21	1.21	1.21	0.99	1.21	1.44	1.67	1.67	1.67
	20	18.4	0.51	0.64	0.77	0.90	0.99	0.99	0.71	0.89	1.08	1.26	1.38	1.38	0.98	1.23	1.49	1.75	1.92	1.92
	30	26.1	0.47	0.61	0.76	0.91	1.06	1.12	0.65	0.86	1.07	1.27	1.48	1.57	0.88	1.18	1.47	1.77	2.07	2.18
	40	35.0	0.47	0.61	0.76	0.91	1.06	1.12	0.65	0.86	1.07	1.27	1.48	1.57	0.88	1.18	1.47	1.77	2.07	2.18
CRO(T)-10 30/110	0	6.5	1.64	1.64	1.64	1.64	1.64	1.64	2.32	2.32	2.32	2.32	2.32	2.32	3.26	3.26	3.26	3.26	3.26	3.26
	10	12.0	1.88	1.88	1.88	1.88	1.88	1.88	2.65	2.65	2.65	2.65	2.65	2.65	3.74	3.74	3.74	3.74	3.74	3.74
	20	18.4	1.77	2.14	2.14	2.14	2.14	2.14	2.50	3.02	3.02	3.02	3.02	3.02	3.53	4.25	4.25	4.25	4.25	4.25
	30	26.1	1.30	2.22	2.42	2.42	2.42	2.42	1.83	3.14	3.42	3.42	3.42	3.42	2.58	4.43	4.81	4.81	4.81	4.81
	40	35.0	1.53	1.57	2.61	2.72	2.72	2.72	0.74	2.22	3.69	3.85	3.85	3.85	1.04	3.12	5.21	5.42	5.42	5.42

REFRIGERANT 404A - CAPACITIES – TONS

Capacities based on 100°F condensing temperature, 10°F superheat and 0°F subcooling

Type and Adjustment Range	Design Evaporator Temperature °F	Saturated Suction Pressure – psig (Reference)	Pressure Drop Across Valve (psi)																	
			0.5						1						2					
			Valve Settings (psig)																	
			10	20	30	40	50	60	10	20	30	40	50	60	10	20	30	40	50	60
CRO-4 0/20	-40	4.6	0.06	0.07	–	–	–	–	0.09	0.10	–	–	–	–	0.11	0.13	–	–	–	–
	-30	9.9	–	0.08	–	–	–	–	–	0.12	–	–	–	–	–	0.16	–	–	–	–
	-20	16.3	–	0.08	–	–	–	–	–	0.11	–	–	–	–	–	0.15	–	–	–	–
CRO-4 0/50	-40	4.6	0.05	0.07	0.07	0.07	0.07	–	0.07	0.09	0.10	0.10	0.10	–	0.10	0.12	0.13	0.13	0.13	–
	-30	9.9	–	0.07	0.08	0.08	0.08	–	–	0.10	0.12	0.12	0.12	–	–	0.13	0.16	0.16	0.16	–
	-20	16.3	–	0.07	0.09	0.10	0.10	–	–	0.09	0.12	0.14	0.14	–	–	0.13	0.16	0.19	0.19	–
	-10	24.0	–	–	0.08	0.11	0.11	–	–	–	0.12	0.15	0.16	–	–	–	0.14	0.20	0.22	–
	0	33.0	–	–	–	0.10	0.12	–	–	–	–	0.14	0.17	–	–	–	–	0.19	0.24	–
10	43.5	–	–	–	–	0.11	–	–	–	–	–	0.16	–	–	–	–	–	0.22	–	
CRO-4 0/75	-40	4.6	0.05	0.06	0.07	0.07	0.07	0.07	0.07	0.09	0.10	0.10	0.10	0.10	0.09	0.11	0.13	0.13	0.13	0.13
	-30	9.9	–	0.07	0.08	0.08	0.08	0.08	–	0.09	0.11	0.12	0.12	0.12	–	0.12	0.15	0.16	0.16	0.16
	-20	16.3	–	0.07	0.08	0.10	0.10	0.10	–	0.09	0.11	0.14	0.14	0.14	–	0.13	0.15	0.19	0.19	0.19
	-10	24.0	–	–	0.08	0.10	0.11	0.11	–	–	0.11	0.14	0.16	0.16	–	–	0.14	0.19	0.22	0.22
	0	33.0	–	–	–	0.09	0.11	0.13	–	–	–	0.13	0.16	0.18	–	–	–	0.18	0.22	0.25
	10	43.5	–	–	–	–	0.11	0.13	–	–	–	–	0.15	0.18	–	–	–	–	0.21	0.25
20	55.7	–	–	–	–	–	0.12	–	–	–	–	–	0.16	–	–	–	–	–	0.23	

Type and Adjustment Range	Design Evaporator Temperature °F	Saturated Suction Pressure – psig (Reference)	Pressure Drop Across Valve (psi)																	
			0.5						1						2					
			Valve Settings (psig)																	
			10	20	30	40	50	60	10	20	30	40	50	60	10	20	30	40	50	60
CRO(T)-6 0/60	-40	4.6	0.16	0.26	0.36	0.46	0.49	0.49	0.22	0.36	0.50	0.63	0.68	0.68	0.28	0.48	0.67	0.86	0.94	0.94
	-20	16.3	–	0.20	0.33	0.46	0.60	0.67	–	0.28	0.46	0.62	0.85	0.93	–	0.37	0.63	0.89	1.17	1.30
	-10	24.0	–	–	0.27	0.42	0.58	0.72	–	–	0.37	0.59	0.81	1.01	–	–	0.51	0.81	1.13	1.40
	0	33.0	–	–	–	0.33	0.51	0.67	–	–	–	0.45	0.71	0.94	–	–	–	0.62	0.99	1.30
	10	43.5	–	–	–	–	0.38	0.55	–	–	–	–	0.52	0.78	–	–	–	–	0.72	1.08
	20	55.7	–	–	–	–	–	0.36	–	–	–	–	–	0.50	–	–	–	–	–	0.68
CRO(T)-10 0/60	-40	4.6	0.33	0.94	1.07	1.07	1.07	1.07	0.46	1.32	1.51	1.51	1.51	1.51	0.63	1.86	2.12	2.12	2.12	2.12
	-20	16.3	–	0.30	1.13	1.45	1.45	1.45	–	0.43	1.59	2.04	2.04	2.04	–	0.59	2.24	2.88	2.88	2.88
	-10	24.0	–	–	0.58	1.51	1.67	1.67	–	–	0.81	2.14	2.35	2.35	–	–	1.14	3.01	3.32	3.32
	0	33.0	–	–	–	0.76	1.91	1.91	–	–	–	1.07	2.69	2.69	–	–	–	1.51	3.80	3.80
	10	43.5	–	–	–	–	0.88	1.99	–	–	–	–	1.24	2.82	–	–	–	–	1.75	3.97
	20	55.7	–	–	–	–	–	0.57	–	–	–	–	–	0.80	–	–	–	–	–	1.12

Type and Adjustment Range	Design Evaporator Temperature °F	Saturated Suction Pressure – psig (Reference)	Pressure Drop Across Valve (psi)																	
			0.5						1						2					
			Valve Settings (psig)																	
			40	50	60	70	80	90	40	50	60	70	80	90	40	50	60	70	80	90
CRO(T)-6 30/110	0	33.0	0.29	0.41	0.52	0.63	0.76	0.86	0.40	0.57	0.72	0.89	1.07	1.21	0.54	0.79	1.00	1.23	1.49	1.69
	10	43.5	–	0.33	0.45	0.58	0.73	0.84	–	0.46	0.63	0.82	1.02	1.18	–	0.63	0.87	1.13	1.43	1.65
	20	55.7	–	–	0.33	0.48	0.64	0.77	–	–	0.46	0.67	0.90	1.08	–	–	0.63	0.93	1.26	1.51
	30	69.7	–	–	–	–	0.49	0.63	–	–	–	–	0.68	0.88	–	–	–	–	0.95	1.23
	40	85.7	–	–	–	–	–	0.40	–	–	–	–	–	0.57	–	–	–	–	–	0.78
CRO(T)-10 30/110	0	33.0	0.52	1.29	1.91	1.91	1.91	1.91	0.73	1.83	2.69	2.69	2.69	2.69	1.02	2.57	3.80	3.80	3.80	3.80
	10	43.5	–	0.60	1.35	2.17	2.17	2.17	–	0.84	1.91	3.06	3.06	3.06	–	1.18	2.69	4.32	4.32	4.32
	20	55.7	–	–	0.39	1.33	2.36	2.45	–	–	0.54	1.87	3.33	3.46	–	–	0.76	2.64	4.70	4.89
	30	69.7	–	–	–	–	1.17	2.07	–	–	–	–	1.66	2.92	–	–	–	–	2.34	4.13
	40	85.7	–	–	–	–	–	0.42	–	–	–	–	–	0.60	–	–	–	–	–	0.84

REFRIGERANT 507 - CAPACITIES – TONS

Capacities based on 100°F condensing temperature, 10°F superheat and 0°F subcooling

Type and Adjustment Range	Design Evaporator Temperature °F	Saturated Suction Pressure – psig (Reference)	Pressure Drop Across Valve (psi)																	
			0.5						1						2					
			Valve Settings (psig)																	
10	20	30	40	50	60	10	20	30	40	50	60	10	20	30	40	50	60			
CRO-4 0/20	-40	5.5	0.06	0.07	–	–	–	–	0.08	0.10	–	–	–	–	0.11	0.13	–	–	–	–
	-30	11.1	–	0.08	–	–	–	–	–	0.12	–	–	–	–	–	0.16	–	–	–	–
	-20	17.8	–	0.07	–	–	–	–	–	0.10	–	–	–	–	–	0.13	–	–	–	–
CRO-4 0/50	-40	5.5	0.05	0.06	0.07	0.07	0.07	–	0.07	0.09	0.10	0.10	0.10	–	0.09	0.12	0.13	0.13	0.13	–
	-30	11.1	–	0.07	0.08	0.08	0.08	–	–	0.09	0.12	0.12	0.12	–	–	0.13	0.16	0.16	0.16	–
	-20	17.8	–	0.06	0.08	0.10	0.10	–	–	0.09	0.12	0.14	0.14	–	–	0.12	0.16	0.19	0.19	–
	-10	25.8	–	–	0.08	0.10	0.11	–	–	–	0.11	0.14	0.16	–	–	–	0.15	0.20	0.22	–
	0	35.2	–	–	–	0.09	0.12	–	–	–	–	0.13	0.16	–	–	–	–	0.18	0.23	–
10	46.2	–	–	–	–	0.10	–	–	–	–	–	0.14	–	–	–	–	–	0.20	–	
CRO-4 0/75	-40	5.5	0.05	0.06	0.07	0.07	0.07	0.07	0.07	0.08	0.10	0.10	0.10	0.10	0.09	0.11	0.13	0.13	0.13	0.13
	-30	11.1	–	0.06	0.08	0.08	0.08	0.08	–	0.09	0.11	0.12	0.12	0.12	–	0.12	0.15	0.16	0.16	0.16
	-20	17.8	–	0.06	0.08	0.09	0.10	0.10	–	0.09	0.11	0.14	0.14	0.14	–	0.12	0.15	0.18	0.19	0.19
	-10	25.8	–	–	0.08	0.09	0.11	0.11	–	–	0.11	0.13	0.16	0.16	–	–	0.15	0.18	0.22	0.22
	0	35.2	–	–	–	0.09	0.11	0.13	–	–	–	0.13	0.15	0.18	–	–	–	0.17	0.21	0.25
	10	46.2	–	–	–	0.08	0.10	0.12	–	–	–	–	0.14	0.17	–	–	–	–	0.19	0.24
20	58.8	–	–	–	–	–	0.11	–	–	–	–	–	0.15	–	–	–	–	–	0.21	

Type and Adjustment Range	Design Evaporator Temperature °F	Saturated Suction Pressure – psig (Reference)	Pressure Drop Across Valve (psi)																	
			0.5						1						2					
			Valve Settings (psig)																	
10	20	30	40	50	60	10	20	30	40	50	60	10	20	30	40	50	60			
CRO(T)-6 0/60	-40	5.5	0.15	0.25	0.35	0.44	0.49	0.49	0.21	0.35	0.48	0.62	0.68	0.68	0.26	0.46	0.65	0.85	0.93	0.93
	-20	17.8	–	–	0.31	0.44	0.57	0.66	–	–	0.43	0.62	0.80	0.93	–	–	0.59	0.85	1.10	1.29
	-10	25.8	–	–	0.24	0.39	0.54	0.69	–	–	0.33	0.54	0.75	0.97	–	–	0.45	0.75	1.04	1.35
	0	35.2	–	–	–	0.29	0.45	0.63	–	–	–	0.40	0.63	0.88	–	–	–	0.54	0.87	1.23
	10	46.2	–	–	–	–	0.30	0.50	–	–	–	–	0.42	0.71	–	–	–	–	0.58	0.98
CRO(T)-10 0/60	-40	5.5	0.27	0.88	1.06	1.06	1.06	1.06	0.37	1.24	1.50	1.50	1.50	1.50	0.52	1.75	2.11	2.11	2.11	2.11
	-20	17.8	–	–	0.99	1.44	1.44	1.44	–	–	1.40	2.03	2.03	2.03	–	–	1.97	2.86	2.86	2.86
	-10	25.8	–	–	0.39	1.33	1.65	1.65	–	–	0.55	1.88	2.33	2.33	–	–	0.77	2.65	3.29	3.29
	0	35.2	–	–	–	0.52	1.56	1.88	–	–	–	0.73	2.20	2.66	–	–	–	1.03	3.10	3.75
	10	46.2	–	–	–	–	0.44	1.70	–	–	–	–	0.63	2.40	–	–	–	–	0.88	3.30

Type and Adjustment Range	Design Evaporator Temperature °F	Saturated Suction Pressure – psig (Reference)	Pressure Drop Across Valve (psi)																	
			0.5						1						2					
			Valve Settings (psig)																	
40	50	60	70	80	90	40	50	60	70	80	90	40	50	60	70	80	90			
CRO(T)-6 30/110	0	35.2	0.26	0.37	0.49	0.61	0.71	0.83	0.36	0.52	0.69	0.85	1.00	1.17	0.49	0.71	0.95	1.18	1.40	1.63
	10	46.2	–	–	0.42	0.55	0.67	0.80	–	–	0.58	0.77	0.94	1.13	–	–	0.80	1.07	1.31	1.58
	20	58.8	–	–	–	0.43	0.57	0.72	–	–	–	0.60	0.80	1.01	–	–	–	0.84	1.12	1.42
	30	73.3	–	–	–	–	0.40	0.57	–	–	–	–	0.56	0.80	–	–	–	–	0.78	1.12
CRO(T)-10 30/110	0	35.2	0.36	1.06	1.81	1.88	1.88	1.88	0.50	1.49	2.55	2.66	2.66	2.66	0.70	2.10	3.60	3.75	3.75	3.75
	10	46.2	–	–	1.15	1.98	2.14	2.14	–	–	1.63	2.80	3.02	3.02	–	–	2.30	3.95	4.26	4.26
	20	58.8	–	–	–	1.07	1.94	2.41	–	–	–	1.51	2.74	3.41	–	–	–	2.12	3.86	4.81
	30	73.3	–	–	–	–	0.67	1.73	–	–	–	–	0.95	2.44	–	–	–	–	1.33	3.44

ORDERING INSTRUCTIONS

To eliminate delays in shipments, specify complete valve designation:

CRO	T	10	0/60	1-1/8 ODF
Valve Type Close on Rise of Outlet Pressure	Access Valve on Inlet Connection CROT-6 or CROT-10	Port Size in Eighths of an Inch	Adjustment Range - psig See Specifications for available adjustment ranges	Connections - ODF Solder or SAE Flare

