



# Instructions for upsizing/downsizing ports on the (S)ORIT-PI Valves

(for product dated 3204 or later)

Once the system (or circuit) has been properly pumped down, and refrigerant has been removed:

1. On SORIT-PI models, switch off power to solenoid coil, and remove coil from solenoid enclosing tube.
2. Loosen the cap screws evenly, disconnect the external bleed flare nut, and remove the pilot valve assembly, piston sleeve, and piston assembly.

**NOTE: For proper valve operation, DO NOT REUSE old piston. New piston supplied with kit MUST be used.**

3. The (S)ORIT-PI-4 and (S)ORIT-PI-5 seats are an integral part of the body, and are not removable. The throat of these valves are threaded, and will accept smaller seats to reduce the valve size. Therefore, not every valve upsizing/downsizing will require removing an old seat and/or adding a new seat. Refer to Table 1 for upsizing/downsizing instructions. When necessary, remove the old seat. If required, insert the new seat into the threaded throat (with O-Ring) and torque to 9 ft.-lbs.

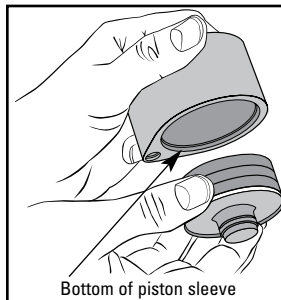

4. Install the guide pin with O-Ring. Reassemble using new piston assembly and body O-Rings. If piston was removed from piston sleeve, insert piston from bottom of piston sleeve to prevent damage to the piston cup seal.

5. Replace body O-Ring on pilot valve assembly. Place the pilot valve assembly on top of piston sleeve. Evenly tighten cap screws to 25 ft.-lbs. Reconnect external bleed flare nut.
6. On SORIT-PI models, reinstall solenoid coil. Switch on power to the solenoid coil.
7. Check the valve for leaks, evacuate, and restart system (circuit).
8. Apply new label to adjustable element reflecting corrected valve size. If the valve has the solenoid stop feature, a new nameplate is also provided and should be replaced.
9. Adjust pilot assembly for desired evaporator setting.

**Table 1**

Current Valve Size	Desired Valve Size	Remove Existing Seat	Install New Seat	Piston Assembly and Seat Kit
(S)ORIT-PI-2	(S)ORIT-PI-3	Yes	Yes	SK-PI-4 to 3
(S)ORIT-PI-2	(S)ORIT-PI-4	Yes	No	SK-PI-4*
(S)ORIT-PI-3	(S)ORIT-PI-2	Yes	Yes	SK-PI-4 to 2
(S)ORIT-PI-3	(S)ORIT-PI-4	Yes	No	SK-PI-4*
(S)ORIT-PI-4	(S)ORIT-PI-2	N/A	Yes	SK-PI-4 to 2
(S)ORIT-PI-4	(S)ORIT-PI-3	N/A	Yes	SK-PI-4 to 3
(S)ORIT-PI-5	(S)ORIT-PI-3	N/A	Yes	SK-PI-5 to 3
(S)ORIT-PI-5	(S)ORIT-PI-4	N/A	Yes	SK-PI-5 to 4

\* Seat not supplied or required.

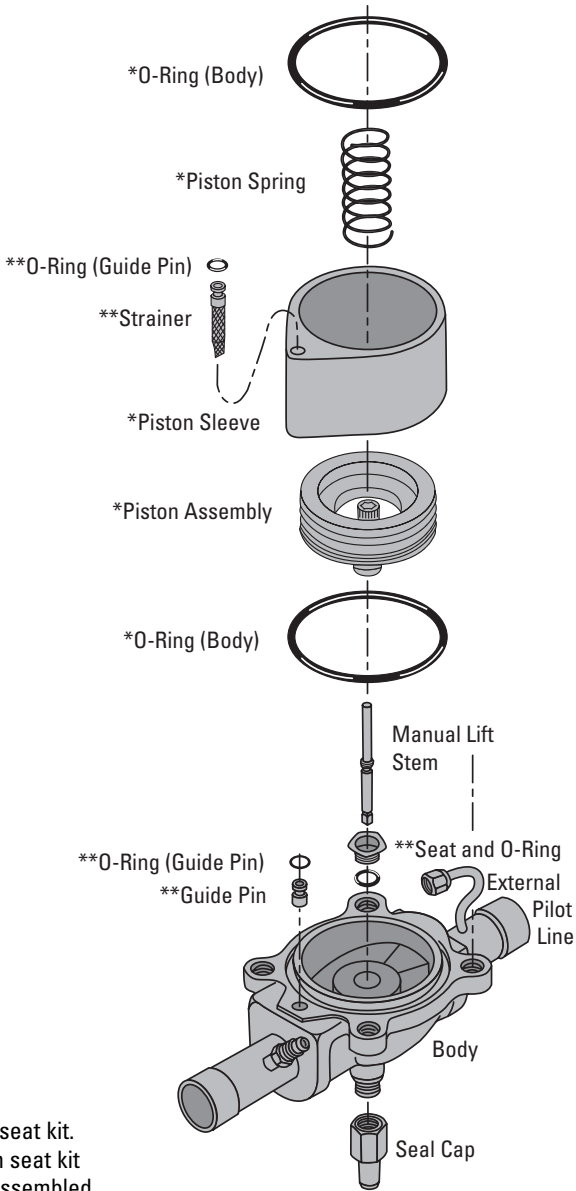

\* Supplied in seat kit.  
 \*\* Supplied in seat kit  
 with O-Ring assembled.

